

# High Resolution Digital Biosensor for Wearable Applications with I<sup>2</sup>C Interface

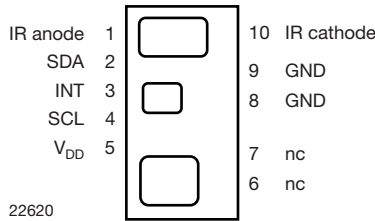
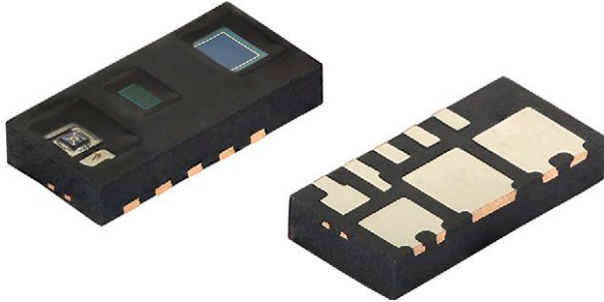

## DESCRIPTION

The VCNL4020C is a fully integrated biosensor and ambient light sensor. Fully integrated means that the infrared emitter is included in the package. It has 16 bit resolution. It includes a signal processing IC and features standard I<sup>2</sup>C communication interface. It features an interrupt function.

## APPLICATIONS

- Wearables
- Health monitoring
- Pulse oximetry

## FEATURES

- Package type: surface mount
- Package form: SMD
- Dimensions (L x W x H in mm): 4.90 x 2.40 x 0.83
- Integrated modules: infrared emitter (IRED), ambient light sensor (ALS), photo diode (PD), and signal conditioning IC
- Interrupt function
- Supply voltage range V<sub>DD</sub>: 2.5 V to 3.6 V
- Supply voltage range IR anode: 2.5 V to 5 V
- Communication via I<sup>2</sup>C interface
- I<sup>2</sup>C bus H-level range: 1.7 V to 5 V
- Floor life: 72 h, MSL 4, according to J-STD-020
- Low stand by current consumption: 1.5  $\mu$ A
- Material categorization: for definitions of compliance please see [www.vishay.com/doc?99912](http://www.vishay.com/doc?99912)



## OPTICAL BIOSENSORS FUNCTION

- Built-in infrared emitter and broader sensitivity photodiode allows to also work with green and red LEDs
- 16 bit effective resolution ensures excellent cross talk immunity
- Programmable LED drive current from 10 mA to 200 mA in 10 mA steps
- Excellent ambient light suppression through signal modulation

## AMBIENT LIGHT FUNCTION

- Built-in ambient light photo-pin-diode with close-to-human-eye sensitivity
- 16 bit dynamic range from 0.25 lx to 16 klx
- 100 Hz and 120 Hz flicker noise rejection

PRODUCT SUMMARY							
PART NUMBER	OPERATING VOLTAGE RANGE (V)	I <sup>2</sup> C BUS VOLTAGE RANGE (V)	LED PULSE CURRENT <sup>(1)</sup> (mA)	AMBIENT LIGHT RANGE (lx)	SPECTRAL BANDWIDTH RANGE $\lambda_{0.5}$ (nm)	OUTPUT CODE	ADC RESOLUTION BIOSENSOR / AMBIENT LIGHT SENSOR
VCNL4020C	2.5 to 3.6	1.7 to 5	10 to 200	0.25 to 16 383	550 to 970	16 bit, I <sup>2</sup> C	16 bit / 16 bit

### Note

<sup>(1)</sup> Adjustable through I<sup>2</sup>C interface



ORDERING INFORMATION			
ORDERING CODE	PACKAGING	VOLUME <sup>(1)</sup>	REMARKS
VCNL4020C-GS08	Tape and reel	MOQ: 3300 pcs	4.90 mm x 2.40 mm x 0.83 mm
VCNL4020C-GS18		MOQ: 13 000 pcs	
SENSORSTARTERKIT <sup>(2)</sup>	-	MOQ: 1 pc	-

**Notes**

<sup>(1)</sup> MOQ: minimum order quantity

<sup>(2)</sup> A sensor starter kit is available, along with an add-on demo board for each of the sensors.

Please visit [www.vishay.com/moreinfo/vcnldemokit/](http://www.vishay.com/moreinfo/vcnldemokit/) for more information.

Contact any catalog distributor or a local Vishay sales representative to purchase the sensor starter kit and contact [sensorstechsupport@vishay.com](mailto:sensorstechsupport@vishay.com) to receive an add-on sensor board.

ABSOLUTE MAXIMUM RATINGS ( $T_{amb} = 25\text{ }^{\circ}\text{C}$ , unless otherwise specified)					
PARAMETER	TEST CONDITION	SYMBOL	MIN.	MAX.	UNIT
Supply voltage		$V_{DD}$	-0.3	5.5	V
Operation temperature range		$T_{amb}$	-25	+85	$^{\circ}\text{C}$
Storage temperature range		$T_{stg}$	-25	+85	$^{\circ}\text{C}$
Total power dissipation	$T_{amb} \leq 25\text{ }^{\circ}\text{C}$	$P_{tot}$	-	50	mW
Junction temperature		$T_j$	-	100	$^{\circ}\text{C}$

BASIC CHARACTERISTICS ( $T_{amb} = 25\text{ }^{\circ}\text{C}$ , unless otherwise specified)						
PARAMETER	TEST CONDITION	SYMBOL	MIN.	TYP.	MAX.	UNIT
Supply voltage $V_{DD}$			2.5	-	3.6	V
Supply voltage IR anode			2.5	-	5	V
I <sup>2</sup> C bus H-level range			1.7	-	5	V
INT H-level range			1.7	-	5	V
INT low voltage	3 mA sink current		-	-	0.4	V
Current consumption	Standby current, no LED-operation		-	1.5	2	$\mu\text{A}$
Current consumption pulse mode incl. LED (averaged)	2 measurements per second, LED current 20 mA		-	5	-	$\mu\text{A}$
	250 measurements per second, LED current 20 mA		-	520	-	$\mu\text{A}$
	2 measurements per second, LED current 200 mA		-	35	-	$\mu\text{A}$
	250 measurements per second, LED current 200 mA		-	4	-	mA
Current consumption ambient light mode	2 measurements per second averaging = 1		-	2.5	-	$\mu\text{A}$
	8 measurements per second averaging = 1		-	10	-	$\mu\text{A}$
	2 measurements per second averaging = 64		-	160	-	$\mu\text{A}$
	8 measurements per second averaging = 64		-	640	-	$\mu\text{A}$
Ambient light resolution	Digital resolution (LSB count)		-	0.25	-	lx
Ambient light output	$E_v = 100\text{ lx}$ averaging = 64		-	400	-	counts
I <sup>2</sup> C clock rate range		$f_{SCL}$	-	-	3400	kHz

**CIRCUIT BLOCK DIAGRAM**

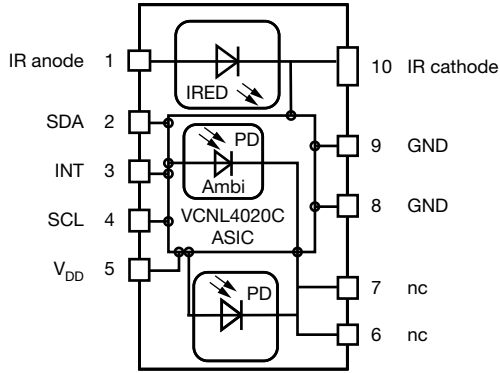

**TEST CIRCUIT**

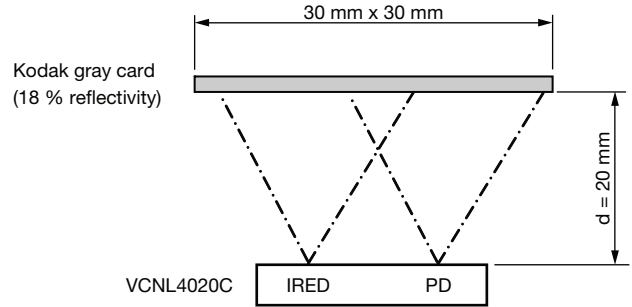

**Note**

- nc must not be electrically connected
- Pads 6 and 7 are only considered as solder pads

**BASIC CHARACTERISTICS** ( $T_{amb} = 25\text{ }^{\circ}\text{C}$ , unless otherwise specified)

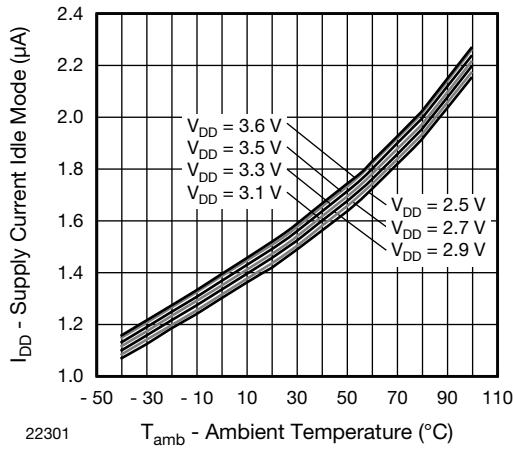

Fig. 1 - Idle Current vs. Ambient Temperature

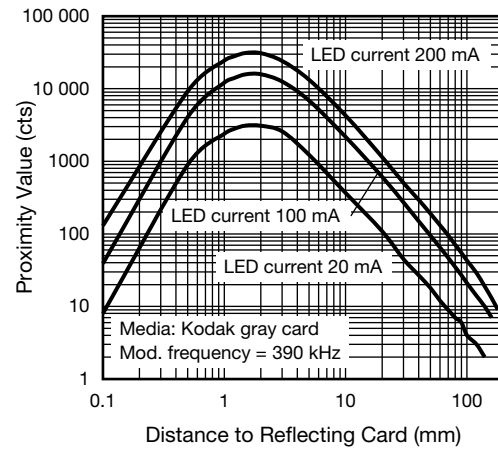

Fig. 3 - Proximity Value vs. Distance

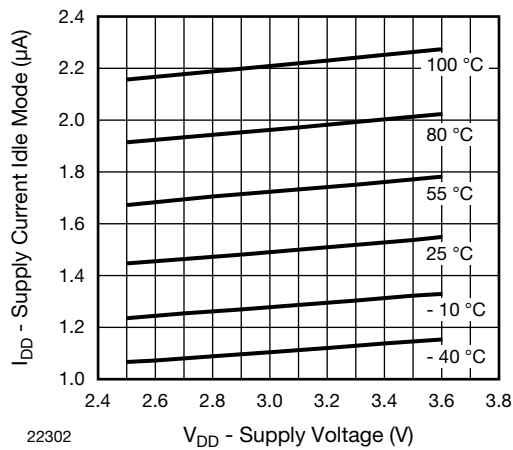

Fig. 2 - Idle Current vs.  $V_{DD}$

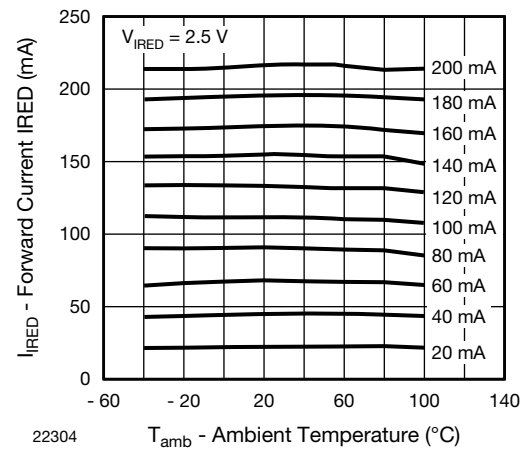

Fig. 4 - Forward Current vs. Temperature

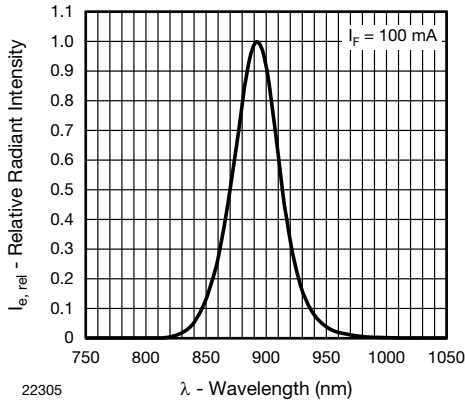

Fig. 5 - Relative Radiant Intensity vs. Wavelength

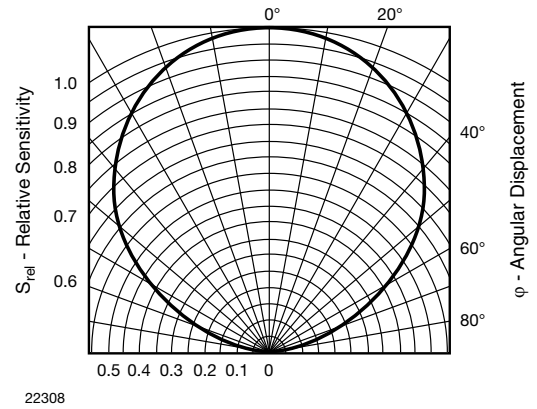

Fig. 8 - Relative Radiant Sensitivity vs. Angular Displacement (Proximity Sensor)

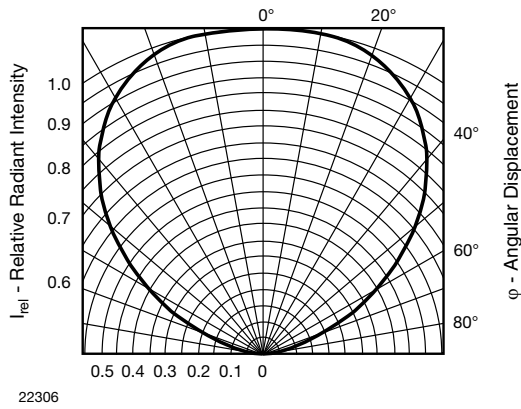

Fig. 6 - Relative Radiant Intensity vs. Angular Displacement

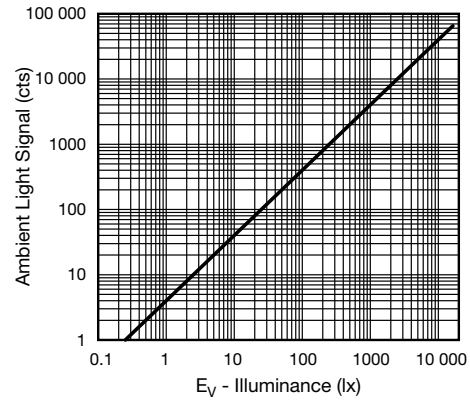

Fig. 9 - Ambient Light Value vs. Illuminance

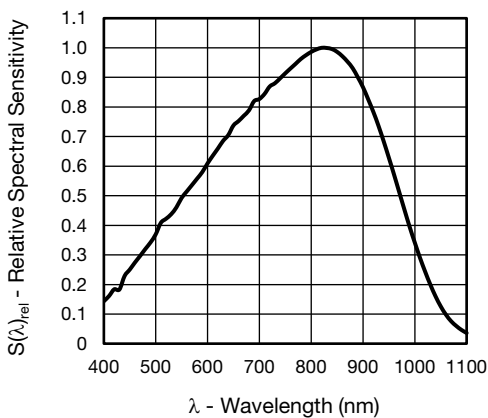

Fig. 7 - Relative Spectral Sensitivity vs. Wavelength (Biosensor)

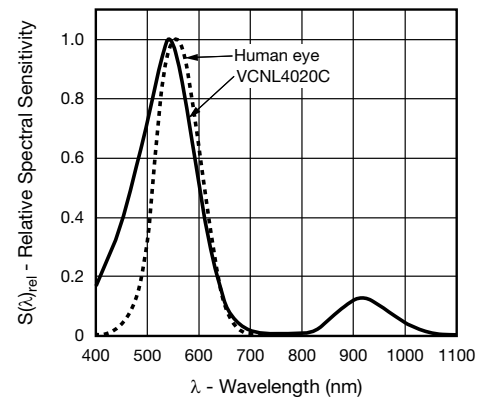
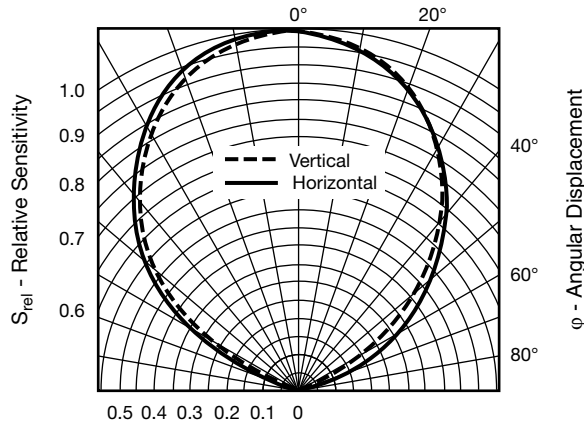

Fig. 10 - Relative Spectral Sensitivity vs. Wavelength (Ambient Light Sensor)



22311

Fig. 11 - Relative Radiant Sensitivity vs. Angular Displacement (Ambient Light Sensor)

**APPLICATION INFORMATION**

The digital biosensor VCNL4020C needs just one decoupling-C at V<sub>DD</sub> if connected to a regulated power supply.

IR cathode needs no external connection as the connection to the driver is done internally, but this allows also for adding external LEDs / IREds to the driver.

**1. Application Circuit**

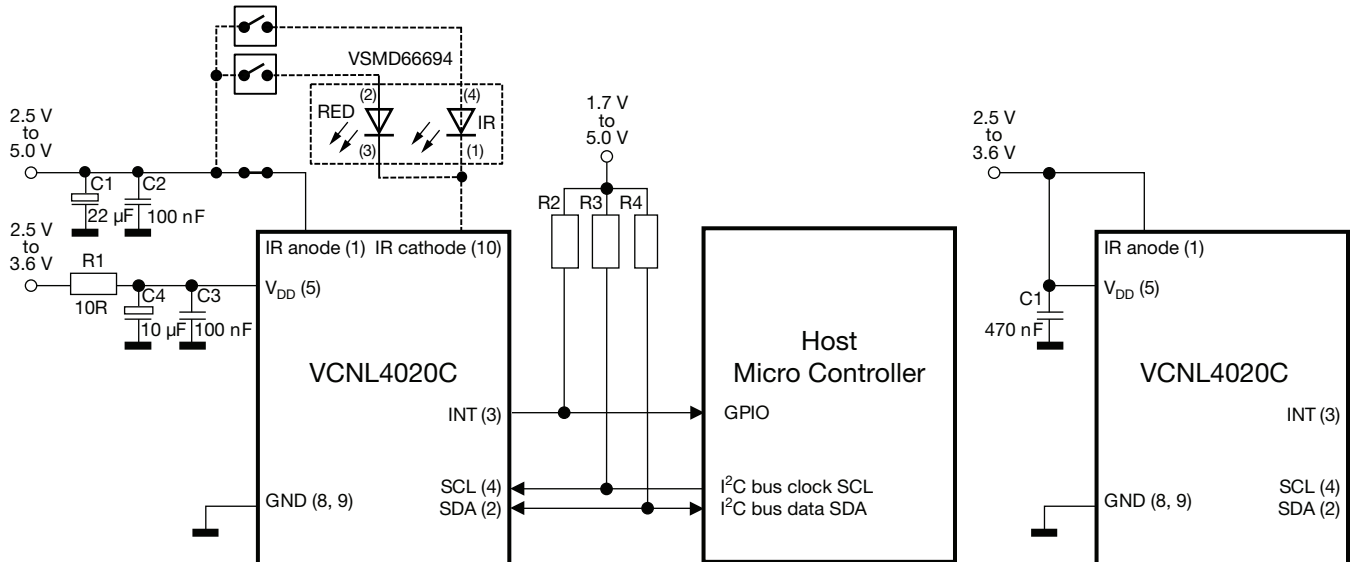

Fig. 12 - Application Circuit (x) = Pin Number

**Note**

- The interrupt pin is an open drain output. The needed pull-up resistor may be connected to the same supply voltage as the application controller and the pull-up resistors at SDA / SCL. Proposed value R2 should be >1 kΩ , e.g. 10 kΩ to 100 kΩ. Proposed value for R3 and R4, e.g. 2.2 kΩ to 4.7 kΩ, depend also on the I<sup>2</sup>C bus speed. For detailed description about set-up and use of the interrupt as well as more application related information see AN: "Designing VCNL4020C into an Application".



## 2. I<sup>2</sup>C Interface

The VCNL4020C contains seventeen 8 bit registers for operation control, parameter setup and result buffering. All registers are accessible via I<sup>2</sup>C communication. Figure 13 shows the basic I<sup>2</sup>C communication with VCNL4020C.

The built in I<sup>2</sup>C interface is compatible with all I<sup>2</sup>C modes (standard, fast and high speed).

I<sup>2</sup>C H-level range = 1.7 V to 5 V.

Please refer to the I<sup>2</sup>C specification from NXP for details.

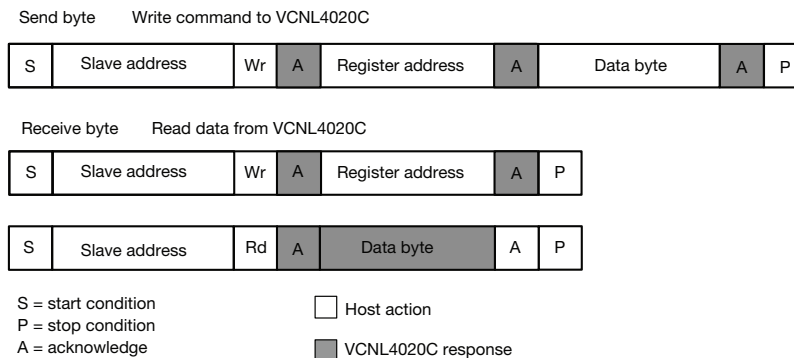

Fig. 13 - Send Byte/Receive Byte Protocol

### Device Address

The VCNL4020C has a fix slave address for the host programming and accessing selection. The predefined 7 bit I<sup>2</sup>C bus address is set to 0010 011 = 13h. The least significant bit (LSB) defines read or write mode. Accordingly the bus address is set to 0010 011x = 26h for write, 27h for read.

### Register Addresses

VCNL4020C has seventeen user accessible 8 bit registers. The register addresses are 80h (register #0) to 90h (register #16).

## REGISTER FUNCTIONS

### Register #0 Command Register

Register address = 80h

The register #0 is for starting ambient light or biosensor measurements. This register contains 2 flag bits for data ready indication.

TABLE 1 - COMMAND REGISTER #0							
Bit 7	Bit 6	Bit 5	Bit 4	Bit 3	Bit 2	Bit 1	Bit 0
config_lock	als_data_rdy	bs_data_rdy	als_od	bs_od	als_en	bs_en	selftimed_en
Description							
config_lock	Read only bit. Value = 1						
als_data_rdy	Read only bit. Value = 1 when ambient light measurement data is available in the result registers. This bit will be reset when one of the corresponding result registers (reg #5, reg #6) is read.						
bs_data_rdy	Read only bit. Value = 1 when biosensor measurement data is available in the result registers. This bit will be reset when one of the corresponding result registers (reg #7, reg #8) is read.						
als_od	R/W bit. Starts a single on-demand measurement for ambient light. If averaging is enabled, starts a sequence of readings and stores the averaged result. Result is available at the end of conversion for reading in the registers #5(HB) and #6(LB).						
bs_od	R/W bit. Starts a single on-demand measurement for biosensor. Result is available at the end of conversion for reading in the registers #7(HB) and #8(LB).						
als_en	R/W bit. Enables periodic als measurement						
bs_en	R/W bit. Enables periodic biosensor measurement						
selftimed_en	R/W bit. Enables state machine and LP oscillator for self timed measurements; no measurement is performed until the corresponding bit is set						

### Note

- With setting bit 3 and bit 4 at the same write command, a simultaneously measurement of ambient light and biosensor is done. Beside als\_en and / or bs\_en first selftimed\_en needs to be set. On-demand measurement modes are disabled if selftimed\_en bit is set. For the selftimed\_en mode changes in reading rates (reg #4 and reg #2) can be made only when b0 (selftimed\_en bit) = 0. For the als\_od mode changes to the reg #4 can be made only when b4 (als\_od bit) = 0; this is to avoid synchronization problems and undefined states between the clock domains. In effect this means that it is only reasonable to change rates while no selftimed conversion is ongoing.



Register #1 Product ID Revision Register

Register address = 81h. This register contains information about product ID and product revision.

Register data value of current revision = 21h.

TABLE 2 - PRODUCT ID REVISION REGISTER #1							
Bit 7	Bit 6	Bit 5	Bit 4	Bit 3	Bit 2	Bit 1	Bit 0
Product ID				Revision ID			
<b>Description</b>							
Product ID		Read only bits. Value = 2					
Revision ID		Read only bits. Value = 1					

Register #2 Rate of Biosensor Measurement

Register address = 82h.

TABLE 3 - BIOSENSOR RATE REGISTER #2							
Bit 7	Bit 6	Bit 5	Bit 4	Bit 3	Bit 2	Bit 1	Bit 0
n/a					Rate of biosensor Measurement (no. of measurements per second)		
<b>Description</b>							
Biosensor rate		R/W bits. 000 - 1.95 measurements/s (DEFAULT) 001 - 3.90625 measurements/s 010 - 7.8125 measurements/s 011 - 16.625 measurements/s 100 - 31.25 measurements/s 101 - 62.5 measurements/s 110 - 125 measurements/s 111 - 250 measurements/s					

Note

- If self\_timed measurement is running, any new value written in this register will not be taken over until the mode is actually cycled.

Register #3 LED Current Setting for Biosensor Mode

Register address = 83h. This register is to set the LED current value for biosensor measurement.

The value is adjustable in steps of 10 mA from 0 mA to 200 mA.

This register also contains information about the used device fuse program ID.

TABLE 4 - LED CURRENT REGISTER #3							
Bit 7	Bit 6	Bit 5	Bit 4	Bit 3	Bit 2	Bit 1	Bit 0
Fuse prog ID		LED current value					
<b>Description</b>							
Fuse prog ID		Read only bits. Information about fuse program revision used for initial setup/calibration of the device.					
LED current value		R/W bits. LED current = Value (dec.) x 10 mA. Valid Range = 0 to 20d. e.g. 0 = 0 mA, 1 = 10 mA, ..., 20 = 200 mA (2 = 20 mA = DEFAULT) LED Current is limited to 200 mA for values higher as 20d.					



Register #4 Ambient Light Parameter Register

Register address = 84h.

TABLE 5 - AMBIENT LIGHT PARAMETER REGISTER #4							
Bit 7	Bit 6	Bit 5	Bit 4	Bit 3	Bit 2	Bit 1	Bit 0
Cont. conv. mode	als_rate			Auto offset compensation	Averaging function (number of measurements per run)		
<b>Description</b>							
Cont. conversion mode	R/W bit. Continuous conversion mode. Enable = 1; Disable = 0 = DEFAULT This function can be used for performing faster ambient light measurements. This mode should only be used with ambient light on-demand measurements. Do not use with self-timed mode. Please refer to the application information chapter 3.3 for details about this function.						
Ambient light measurement rate	R/W bits. Ambient light measurement rate 000 - 1 samples/s 001 - 2 samples/s = DEFAULT 010 - 3 samples/s 011 - 4 samples/s 100 - 5 samples/s 101 - 6 samples/s 110 - 8 samples/s 111 - 10 samples/s						
Auto offset compensation	R/W bit. Automatic offset compensation. Enable = 1 = DEFAULT; Disable = 0 In order to compensate a technology, package or temperature related drift of the ambient light values there is a built in automatic offset compensation function. With active auto offset compensation the offset value is measured before each ambient light measurement and subtracted automatically from actual reading.						
Averaging function	R/W bits. Averaging function. Bit values sets the number of single conversions done during one measurement cycle. Result is the average value of all conversions. Number of conversions = $2^{\text{decimal\_value}}$ e.g. 0 = 1 conv., 1 = 2 conv, 2 = 4 conv., ....7 = 128 conv. DEFAULT = 32 conv. (bit 2 to bit 0: 101)						

Note

- If self\_timed measurement is running, any new value written in this register will not be taken over until the mode is actually cycled.

Register #5 and #6 Ambient Light Result Register

Register address = 85h and 86h. These registers are the result registers for ambient light measurement readings.

The result is a 16 bit value. The high byte is stored in register #5 and the low byte in register #6.

TABLE 6 - AMBIENT LIGHT RESULT REGISTER #5							
Bit 7	Bit 6	Bit 5	Bit 4	Bit 3	Bit 2	Bit 1	Bit 0
<b>Description</b>							
Read only bits. High byte (15:8) of ambient light measurement result							

TABLE 7 - AMBIENT LIGHT RESULT REGISTER #6							
Bit 7	Bit 6	Bit 5	Bit 4	Bit 3	Bit 2	Bit 1	Bit 0
<b>Description</b>							
Read only bits. Low byte (7:0) of ambient light measurement result							





Register #7 and #8 Biosensor Measurement Result Register

Register address = 87h and 88h. These registers are the result registers for biosensor measurement readings.

The result is a 16 bit value. The high byte is stored in register #7 and the low byte in register #8.

TABLE 8 - BIOSENSOR RESULT REGISTER #7							
Bit 7	Bit 6	Bit 5	Bit 4	Bit 3	Bit 2	Bit 1	Bit 0
<b>Description</b>							
Read only bits. High byte (15:8) of biosensor measurement result							

TABLE 9 - BIOSENSOR RESULT REGISTER #8							
Bit 7	Bit 6	Bit 5	Bit 4	Bit 3	Bit 2	Bit 1	Bit 0
<b>Description</b>							
Read only bits. Low byte (7:0) of biosensor measurement result							

Register #9 Interrupt Control Register

Register address = 89h.

TABLE 10 - INTERRUPT CONTROL REGISTER #9							
Bit 7	Bit 6	Bit 5	Bit 4	Bit 3	Bit 2	Bit 1	Bit 0
Int count exceed			n/a	INT_BS_ready_EN	INT_ALS_ready_EN	INT_THRES_EN	INT_THRES_SEL
<b>Description</b>							
Int count exceed	R/W bits. These bits contain the number of consecutive measurements needed above/below the threshold 000 - 1 count = DEFAULT 001 - 2 count 010 - 4 count 011 - 8 count 100 - 16 count 101 - 32 count 110 - 64 count 111 - 128 count						
INT_BS_ready_EN	R/W bit. Enables interrupt generation at biosensor data ready						
INT_ALS_ready_EN	R/W bit. Enables interrupt generation at ambient data ready						
INT_THRES_EN	R/W bit. Enables interrupt generation when high or low threshold is exceeded						
INT_THRES_SEL	R/W bit. If 0: thresholds are applied to biosensor measurements If 1: thresholds are applied to als measurements						



Register #10 and #11 Low Threshold

Register address = 8Ah and 8Bh. These registers contain the low threshold value. The value is a 16 bit word. The high byte is stored in register #10 and the low byte in register #11.

TABLE 11 - LOW THRESHOLD REGISTER #10							
Bit 7	Bit 6	Bit 5	Bit 4	Bit 3	Bit 2	Bit 1	Bit 0
<b>Description</b>							
R/W bits. High byte (15:8) of low threshold value							

TABLE 12 - LOW THRESHOLD REGISTER #11							
Bit 7	Bit 6	Bit 5	Bit 4	Bit 3	Bit 2	Bit 1	Bit 0
<b>Description</b>							
R/W bits. Low byte (7:0) of low threshold value							

Register #12 and #13 High Threshold

Register address = 8Ch and 8Dh. These registers contain the high threshold value. The value is a 16 bit word. The high byte is stored in register #12 and the low byte in register #13.

TABLE 13 - HIGH THRESHOLD REGISTER #12							
Bit 7	Bit 6	Bit 5	Bit 4	Bit 3	Bit 2	Bit 1	Bit 0
<b>Description</b>							
R/W bits. High byte (15:8) of high threshold value							

TABLE 14 - HIGH THRESHOLD REGISTER #13							
Bit 7	Bit 6	Bit 5	Bit 4	Bit 3	Bit 2	Bit 1	Bit 0
<b>Description</b>							
R/W bits. Low byte (7:0) of high threshold value							

Register #14 Interrupt Status Register

Register address = 8Eh. This register contains information about the interrupt status for either biosensor or ALS function and indicates if high or low going threshold exceeded.

TABLE 15 - INTERRUPT STATUS REGISTER #14							
Bit 7	Bit 6	Bit 5	Bit 4	Bit 3	Bit 2	Bit 1	Bit 0
n/a				int_bs_ready	int_als_ready	int_th_low	int_th_hi
<b>Description</b>							
int_bs_ready		R/W bit. Indicates a generated interrupt for biosensor					
int_als_ready		R/W bit. Indicates a generated interrupt for als					
int_th_low		R/W bit. Indicates a low threshold exceed					
int_th_hi		R/W bit. Indicates a high threshold exceed					

Note

- Once an interrupt is generated the corresponding status bit goes to 1 and stays there unless it is cleared by writing a 1 in the corresponding bit. The int pad will be pulled down while at least one of the status bit is 1.



Register #15 Biosensor Modulator Timing Adjustment

Register address = 8Fh.

TABLE 16 - BIOSENSOR MODULATOR TIMING ADJUSTMENT #15							
Bit 7	Bit 6	Bit 5	Bit 4	Bit 3	Bit 2	Bit 1	Bit 0
Modulation delay time			Biosensor frequency		Modulation dead time		
Description							
Modulation delay time		R/W bits. Setting a delay time between LED signal and detectors input signal evaluation. This function is for compensation of delays from LED and photo diode. Also in respect to the possibility for setting different proximity signal frequency. Correct adjustment is optimizing measurement signal level. (DEFAULT = 0)					
Biosensor frequency		R/W bits. Setting the biosensor test signal frequency The biosensor measurement is using a square signal as measurement signal. Four different values are possible: 00 = 390.625 kHz (DEFAULT) 01 = 781.25 kHz 10 = 1.5625 MHz 11 = 3.125 MHz					
Modulation dead time		R/W bits. Setting a dead time in evaluation of LED signal at the slopes of the signal. (DEFAULT = 1) This function is for reducing of possible disturbance effects. This function is reducing signal level and should be used carefully.					

Note

- The settings for best performance will be provided by Vishay. With first samples this is evaluated to: Delay time = 0; dead time = 1 and BS frequency = 00. With that register #15 should be programmed with 1 (= default value).

Register #16 Ambient IR Light Level Register

Register address = 90h.

This register is not intended to be used by customer.

3. IMPORTANT APPLICATION HINTS AND EXAMPLES

3.1 Receiver standby mode

In standby mode the receiver has the lowest current consumption of about 1.5 µA. In this mode only the I2C interface is active. This is always valid, when there are no measurement demands executed. Also the current sink for the LED is inactive, so there is no need for changing register #3 (LED current).

3.2 Data Read

In order to get a certain register value, the register has to be addressed without data like shown in the following scheme. After this register addressing, the data from the addressed register is written after a subsequent read command.

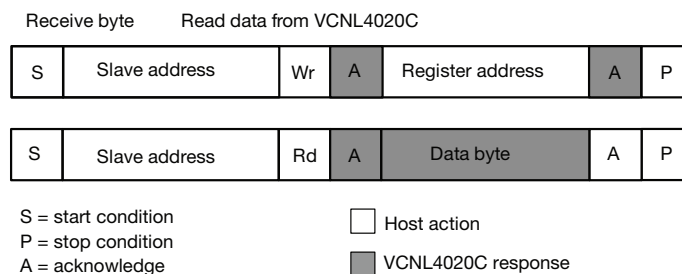

Fig. 14 - Send Byte / Receive Byte Protocol

The stop condition between these write and read sequences is not mandatory. It works also with a repeated start condition.

Note

- For reading out 2 (or more) subsequent registers like the result registers, it is not necessary to address each of the registers separately. After one read command the internal register counter is increased automatically and any subsequent read command is accessing the next register.

Example: read register “Ambient Light Result Register” #5 and #6:

Addressing:command: 26h, 85h (VCNL4020C\_I<sup>2</sup>C\_Bus\_Write\_Adr., Ambient Light Result Register #5 [85])

Read register #5:command: 27h, data (VCNL4020C\_I<sup>2</sup>C\_Bus\_Read\_Adr., {High Byte Data of Ambient Light Result register #5 [85]})

Read register #6:command: 27h, data (VCNL4020C\_I<sup>2</sup>C\_Bus\_Read\_Adr., {Low Byte Data of Ambient Light Result register #6 [86]})

### 3.3 Continuous Conversion Mode in Ambient Light Measurement

In the following is a detail description of the function “continuous conversion” (bit 7 of register #4)

#### Standard mode (bit 7 of reg #4 = 0):

In standard mode the ambient light measurement is done during a fixed time frame of 100 ms. The single measurement itself takes actually only appr. 300  $\mu$ s.

The following figures show examples of this measurement timing in standard mode using averaging function 2 and 8 as examples for illustration (possible values up to 128).

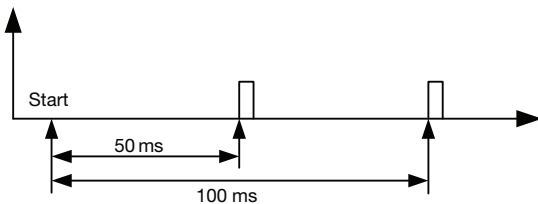

22315

Fig. 15 - Ambient Light Measurement with Averaging = 2; Final Measurement Result = Average of these 2 Measurements

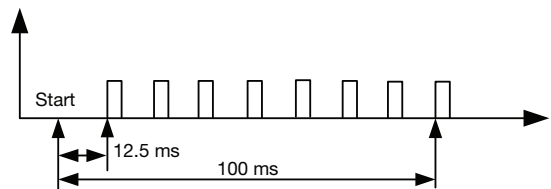

22316

Fig. 16 - Ambient Light Measurement with Averaging = 8; Final Measurement Result = Average of these 8 Measurements

#### Note

- $\geq$  Independent of setting of averaging the result is available only after 100 ms.

#### Continuous conversion mode (bit 7 of register #4 = 1):

In continuous conversion mode the single measurements are done directly subsequent after each other.

See following examples in figure 17 and 18

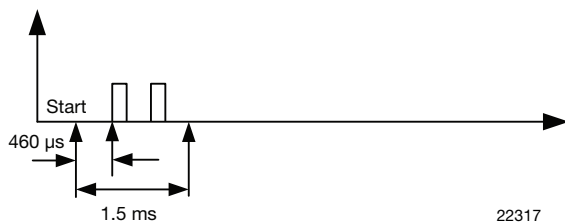

22317

Fig. 17 - Ambient Light Measurement with Averaging = 2; using Continuous Conversion Mode

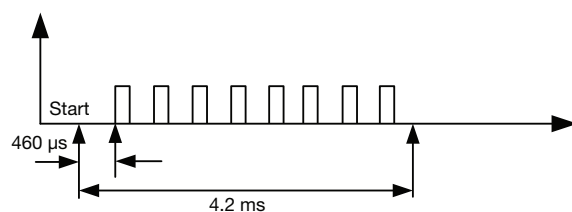

22318

Fig. 18 - Ambient Light Measurement with Averaging = 8; using Continuous Conversion Mode



PACKAGE DIMENSIONS in millimeters

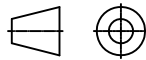
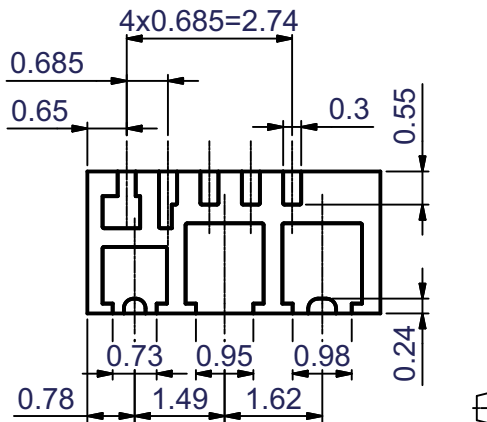

technical drawings according to DIN specifications

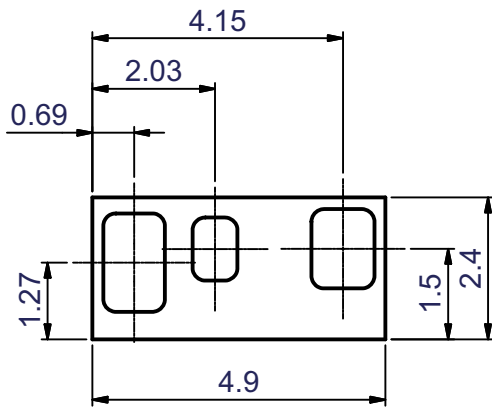
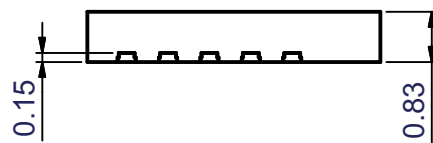

Pinning Bottom view

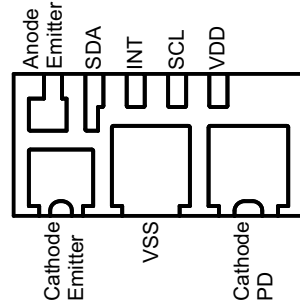

Pinning Top view

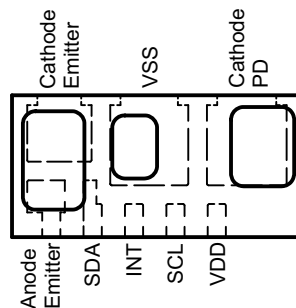

Proposed PCB Footprint

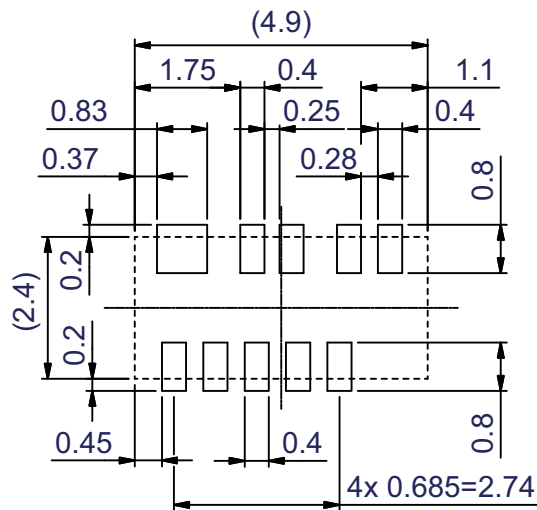

Drawing-No.: 6.550-5319

Not indicated tolerances ± 0.1

**TAPE AND REEL DIMENSIONS** in millimeters

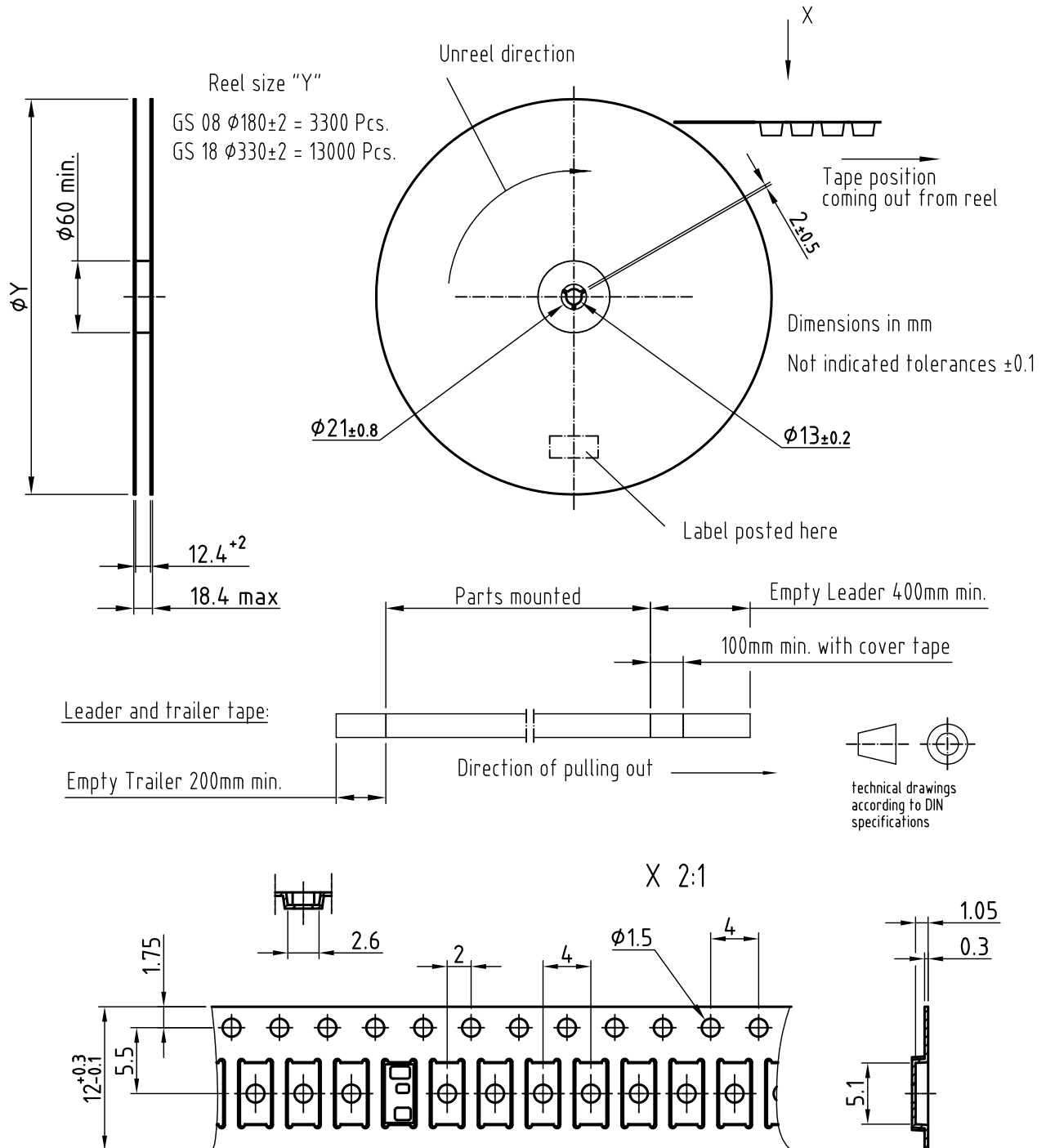

Drawing-No.: 9.700-5387.01-4

**SOLDER PROFILE**

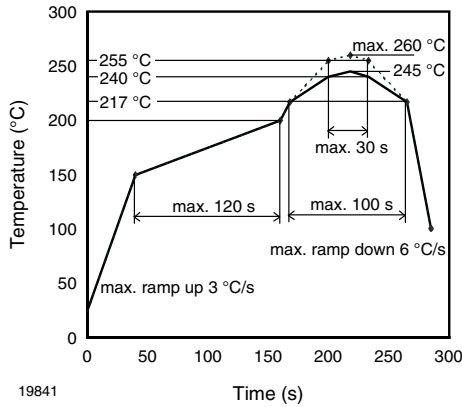

Fig. 19 - Lead (Pb)-free Reflow Solder Profile acc. J-STD-020

**DRYPACK**

Devices are packed in moisture barrier bags (MBB) to prevent the products from moisture absorption during transportation and storage. Each bag contains a desiccant.

**FLOOR LIFE**

Floor life (time between soldering and removing from MBB) must not exceed the time indicated on MBB label:

Floor life: 72 h

Conditions:  $T_{amb} < 30\text{ °C}$ ,  $RH < 60\%$

Moisture sensitivity level 4, acc. to J-STD-020.

**DRYING**

In case of moisture absorption devices should be baked before soldering. Conditions see J-STD-020 or label. Devices taped on reel dry using recommended conditions 192 h at 40 °C (+ 5 °C),  $RH < 5\%$ .



# Designing the VCNL4020C into an Application

By Reinhard Schaar

## INTRODUCTION AND BASIC OPERATION

The VCNL4020C is a fully integrated biosensor and ambient light sensor. It combines an infrared emitter and PIN photodiode for biosensor functionality, ambient light sensor, and signal processing IC in a single package with a 16-bit ADC. The device provides high frequency bursts for biosensor signal measurement, connection of external LEDs / IREds, wide sensitivity down to the green wavelength, and 10 mA current steps for well-aligned signal intensity of connected LEDs / IREds. The VCNL4020C features a miniature leadless package (LLP) for surface mounting in a 4.9 mm x 2.4 mm package, with a low profile of 0.83 mm designed specifically for the low height requirements of wearable applications. Through its standard I<sup>2</sup>C bus serial digital interface, it allows easy access to a “Biosensor Signal” and “Light Intensity” measurements without complex calculations or programming. The programmable interrupt function offers wake-up functionality for the microcontroller when a proximity event or ambient light change occurs, which reduces processing overhead by eliminating the need for continuous polling.

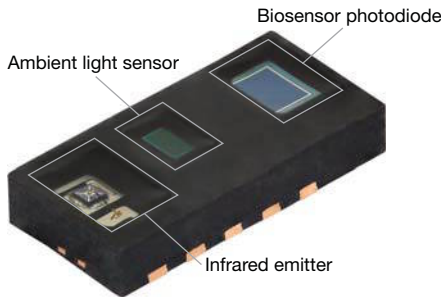

Fig. 1 - VCNL4020C Top View

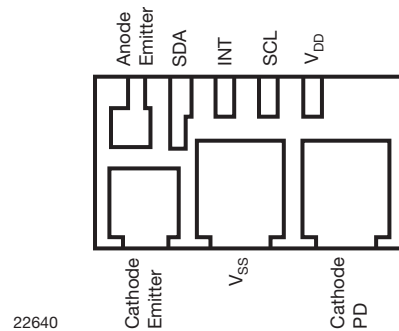

Fig. 2 - VCNL4020C Bottom View

## COMPONENTS (BLOCK DIAGRAM)

The major components of the VCNL4020C are shown in the block diagram.

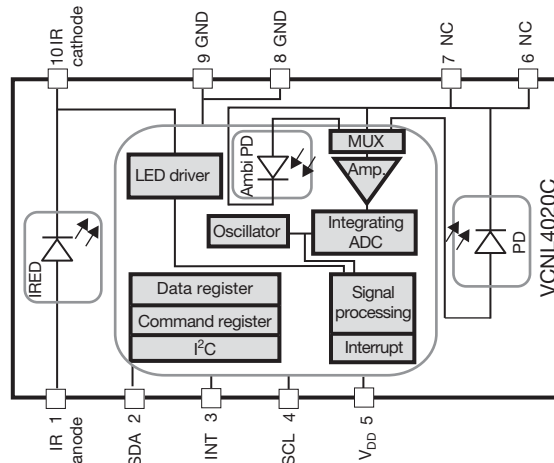

Fig. 3 - VCNL4020C Detailed Block Diagram



## Designing the VCNL4020C into an Application

The integrated **infrared emitter** has a peak wavelength of 890 nm. The infrared emitter spectrum is shown in Fig. 4.

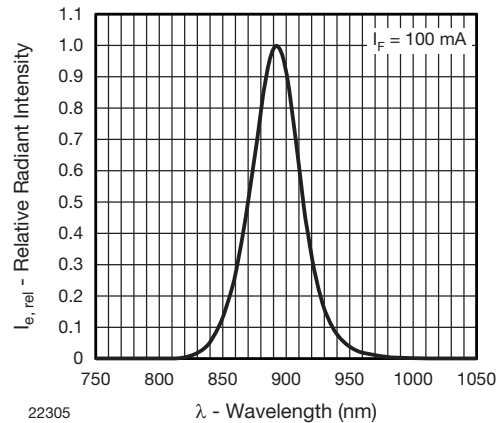

Fig. 4 - Relative Radiant Intensity vs. Wavelength

The infrared emitter has a programmable drive current from 10 mA to 200 mA in 10 mA steps. The infrared light emitted is modulated at one of four user-defined carrier frequencies: 390.625 kHz, 781.25 kHz, 1.5625 MHz (not recommended), or 3.125 MHz (not recommended). The PIN photodiode receives the light that is reflected off the object and converts it to a current. It has a peak sensitivity of 820 nm, and a  $\lambda_{0.5}$  bandwidth of 550 nm to 970 nm. Its sensitivity for LEDs with wavelengths at about 660 nm is about 75 %. This is about same for an IRED coming with a peak of 940 nm. It is insensitive to ambient light. It ignores the DC component of light and “looks for” the pulsed light at one of the two recommended frequencies used by the emitter. Using a modulated signal for proximity provides distinct advantages over other sensors on the market.

The **ambient light sensor** receives the visible light and converts it to a current. The human eye can see light at wavelengths from 380 nm to 780 nm, with a peak of 555 nm.

Vishay’s ambient light sensor closely matches this range of sensitivity. It has peak sensitivity at 540 nm and a bandwidth from 430 nm to 610 nm.

The application-specific integrated circuit, or ASIC, includes an LED driver, I<sup>2</sup>C bus interface, amplifier, integrating analog-to-digital converter, oscillator, and Vishay’s “secret sauce” signal processor. For biosensor functionality, it converts the current from the PIN photodiode to a 16-bit digital data output value. For ambient light sensing, it converts the current from the ambient light detector, amplifies it, and converts it to a 16-bit digital output stream.

### PIN CONNECTIONS

Fig. 3 shows the pin assignments of the VCNL4020C.

The connections include:

- Pin 1 - IR anode to the power supply
- Pin 2 - SDA to microcontroller
- Pin 3 - INT to microcontroller
- Pin 4 - SCL to microcontroller
- Pin 5 - V<sub>DD</sub> to the power supply
- Pin 6, pin 7 - must not be connected
- Pin 8, pin 9 - connect to ground
- Pin 10 - not connected. Used only if external emitters are being used

## Designing the VCNL4020C into an Application

The power supply for the ASIC ( $V_{DD}$ ) has a defined range from 2.5 V to 3.6 V. The infrared emitter may be connected in the range from 2.5 V to 5.0 V. It is best if  $V_{DD}$  is connected to a regulated power supply and pin 1, IR anode, is connected directly to the battery. This eliminates any influence of the high infrared emitter current pulses on the  $V_{DD}$  supply line. The ground pins 8 and 9 are electrically the same. They use the same bottom metal pad and may be routed to the same stable ground plane. The power supply decoupling components shown in Fig. 5 are optional. They isolate the sensor from other possible noise on the same power rail, but in most applications are not needed. If separate power supplies for the  $V_{DD}$  and the infrared emitter are used and there are no negative spikes below 2.5 V, only one capacitor at  $V_{DD}$  could be used. The 100 nF capacitor should be placed close to the  $V_{DD}$  pin. The SCL and SDA, as well as the interrupt lines, need pull-up resistors. The resistor values depend on the application and on the I<sup>2</sup>C bus speed. Common values are about 2.2 k $\Omega$  to 4.7 k $\Omega$  for the SDA and SCL and 10 k $\Omega$  to 100 k $\Omega$  for the interrupt.

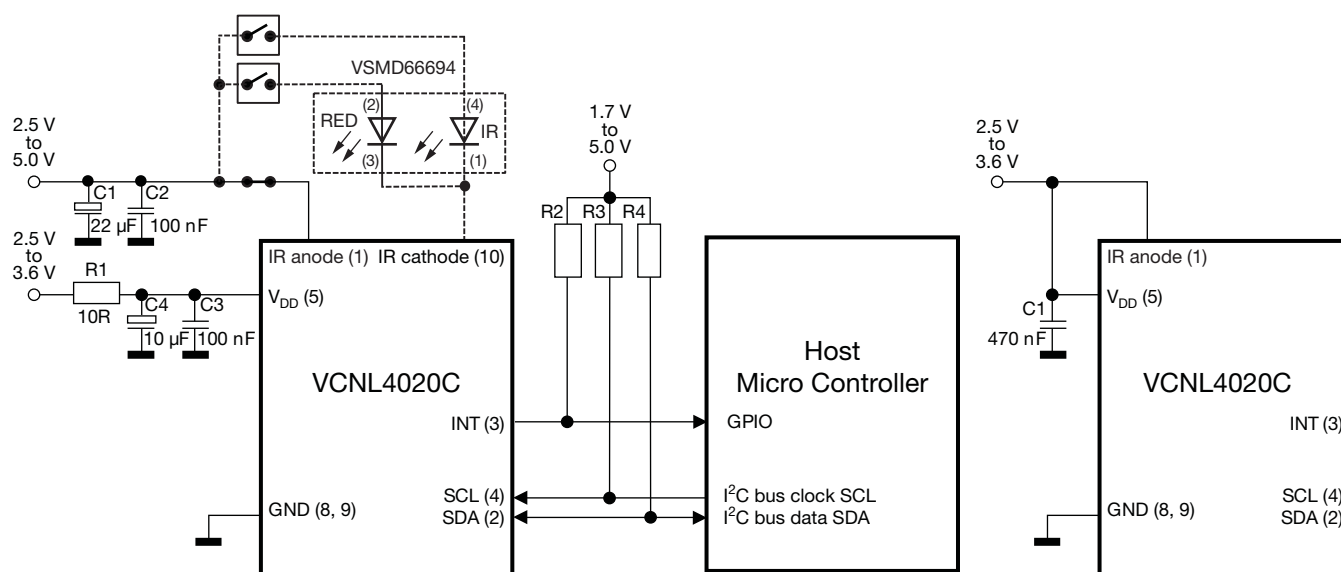

Fig. 5 - VCNL4020C Application Circuit

### Notes

- (1) The pad "IR\_Cathode" pin 10 does not need to be connected, as the connection to the driver is realized internally, but offers the possibility to also use external LEDs / IREDS connected to the sensor.
- (2) The pads 6 and 7 must stay just as solder pads and no disturbing tracks (e.g. SCL or SDA) should be close by.

## Designing the VCNL4020C into an Application

### MECHANICAL DESIGN CONSIDERATIONS

The VCNL4020C is a fully integrated biosensor and ambient light sensor. Competing sensors use a discrete infrared emitter, which leads to complex geometrical calculations to determine the position of the emitter. Competing sensors also require a mechanical barrier between the emitter and detectors to eliminate crosstalk; light reflecting off the inside of the window cover can produce false readings. The VCNL4020C does not require a mechanical barrier. The signal processor continuously compensates for the light reflected from windows, ensuring a proper proximity reading. As a fully integrated sensor, the design process is greatly simplified.

The only dimensions that the design engineer needs to consider are the distance from the top surface of the sensor to the outside surface of the window and the size of the window. These dimensions will determine the size of the detection zone.

The angle of half intensity of the emitter and the angle of half sensitivity of the PIN photodiode are  $\pm 55^\circ$ , as shown in Fig. 6 and Fig. 7.

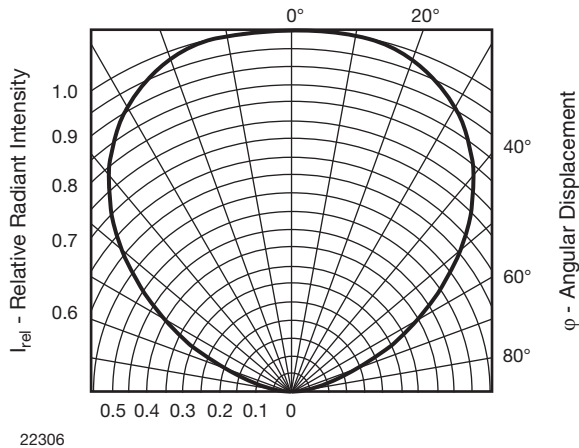

Fig. 6 - Angle of the Half Intensity of the Emitter

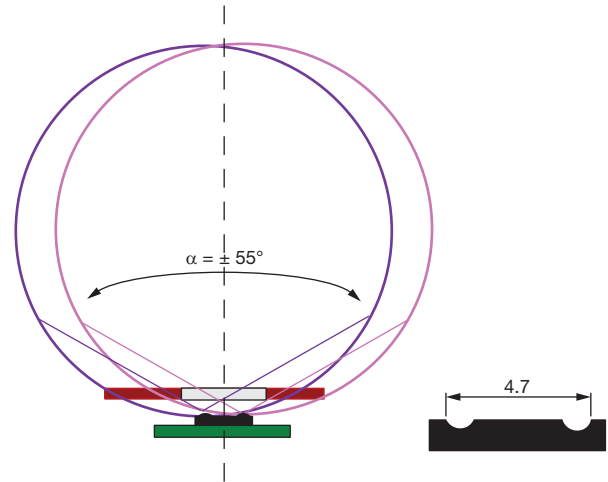

Fig. 8 - Emitter and Detector Angle and Distance

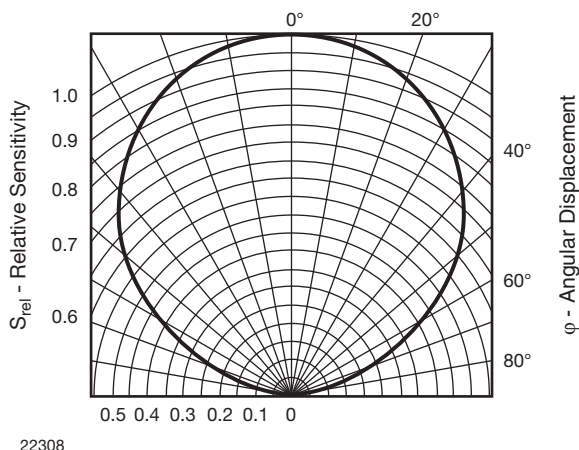

Fig. 7 - Angle of the Half Sensitivity of the PIN Photodiode

The center of the sensor and center of the window should be aligned. Assuming the detection zone is a cone-shaped region with an angle of  $\pm 40^\circ$ , the following are dimensions for the distance from the top surface of the sensor to the outside surface of the glass,  $d$ , and the width of the window,  $w$ . The distance from the outer side of the infrared emitter to the outer side of the PIN photodiode is 4.7 mm. The height of the sensor is 0.83 mm.

## Designing the VCNL4020C into an Application

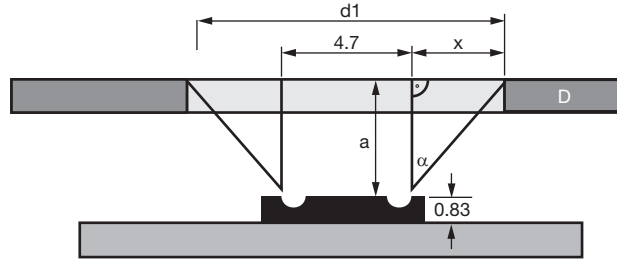

Fig. 9 - Window Dimensions

Width calculations for some distances from 0 mm to 4 mm result with this in:

$a = 0.0 \text{ mm}$	$\rightarrow$	$x = 0.0 \text{ mm}$	$\rightarrow$	$d1 = 4.7 \text{ mm} + 0.0 \text{ mm}$	$= 4.70 \text{ mm}$
$a = 0.5 \text{ mm}$	$\rightarrow$	$x = 0.42 \text{ mm}$	$\rightarrow$	$d1 = 4.7 \text{ mm} + 0.84 \text{ mm}$	$= 5.54 \text{ mm}$
$a = 1.0 \text{ mm}$	$\rightarrow$	$x = 0.84 \text{ mm}$	$\rightarrow$	$d1 = 4.7 \text{ mm} + 1.68 \text{ mm}$	$= 6.38 \text{ mm}$
$a = 1.5 \text{ mm}$	$\rightarrow$	$x = 1.28 \text{ mm}$	$\rightarrow$	$d1 = 4.7 \text{ mm} + 2.56 \text{ mm}$	$= 7.26 \text{ mm}$
$a = 2.0 \text{ mm}$	$\rightarrow$	$x = 1.68 \text{ mm}$	$\rightarrow$	$d1 = 4.7 \text{ mm} + 3.36 \text{ mm}$	$= 8.06 \text{ mm}$
$a = 2.5 \text{ mm}$	$\rightarrow$	$x = 2.10 \text{ mm}$	$\rightarrow$	$d1 = 4.7 \text{ mm} + 4.20 \text{ mm}$	$= 8.90 \text{ mm}$
$a = 3.0 \text{ mm}$	$\rightarrow$	$x = 2.52 \text{ mm}$	$\rightarrow$	$d1 = 4.7 \text{ mm} + 5.04 \text{ mm}$	$= 9.74 \text{ mm}$
$a = 3.5 \text{ mm}$	$\rightarrow$	$x = 2.94 \text{ mm}$	$\rightarrow$	$d1 = 4.7 \text{ mm} + 5.88 \text{ mm}$	$= 10.58 \text{ mm}$
$a = 4.0 \text{ mm}$	$\rightarrow$	$x = 3.36 \text{ mm}$	$\rightarrow$	$d1 = 4.7 \text{ mm} + 6.72 \text{ mm}$	$= 11.42 \text{ mm}$

The results above represent the ideal width of the window. The mechanical design of the device may not allow for this size. Added external LEDs / IREDs will require an increase in the window width accordingly.

### BIOSENSOR

The main DC light sources found in the environment are sunlight and tungsten (incandescent) bulbs. These kinds of disturbance sources will cause a DC current in the detector inside the sensor, which in turn will produce noise in the receiver circuit. The negative influence of such DC light is reduced by a subtraction of the measured current for these disturbing lights, which is also made for each single biosensor measurement. This compensation works up to about 100 klx.

Additional optical filtering of the receiver diode is not needed, but to also allow for the operation of external LEDs down to the green wavelength, the sensitivity for the biosensor photodiode is coming without any daylight filter, as shown in Fig. 10.

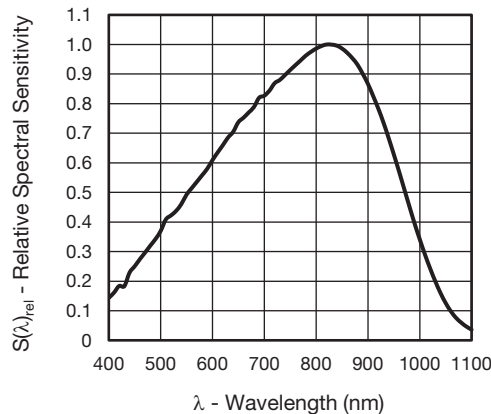

Fig. 10 - Spectral Sensitivity of Proximity PIN Photodiode

## Designing the VCNL4020C into an Application

As mentioned earlier, the biosensor uses a modulated carrier signal on one of four user-selected frequencies. These frequencies are far from the ballast frequencies of fluorescent lights, ensuring that the sensor is unaffected by them. The infrared emitter sends out a series of pulses, a burst, at the selected frequency and the receiver unit sets to this same frequency, receiving the reflected pulses (Fig. 11).

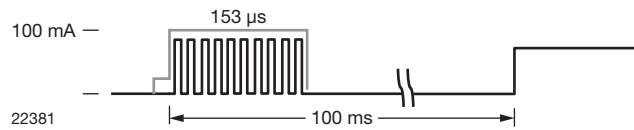

Fig. 11 - Emitter Pulses

In addition to DC light source noise, there is some reflection of the infrared emitted light off the surfaces of the components that surround the VCNL4020C. The distance to the cover, proximity of surrounding components, tolerances of the sensor, defined infrared emitter current, ambient temperature, and type of window material used all contribute to this reflection. The result of the reflection and DC noise produces an output current on the sensing photodiode. This current is converted into a count called the offset count.

In addition to the offset, there is also a small noise floor during the measurement that comes from the DC light suppression circuitry. This noise is in the range from  $\pm 5$  counts to  $\pm 20$  counts. The application should “ignore” this offset and small noise floor by subtracting them from the total readings. The application-specific offset is easily determined during the development of the end product.

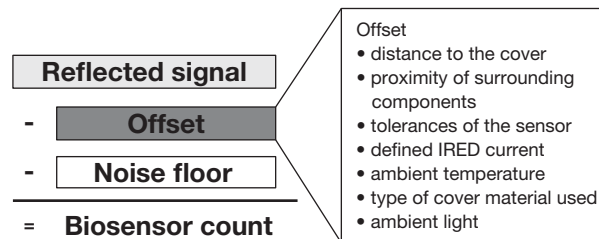

Fig. 12 - Reflected Counts Calculation

Measured digital counts need a well-defined algorithm to extract for heart rate measurement. Higher measurement speed will result in more exact data.

### PROXIMITY CURRENT CONSUMPTION

The standby current of the VCNL4020C is 1.5  $\mu$ A. In this mode, only the I<sup>2</sup>C interface is active. In most consumer electronic applications the sensor will mostly be in standby mode. In wearable applications, the sensor may also need to wake up the application when a finger comes close.

For this, just one or two measurements per second may be enough. For heart rate and pulse oximetry measurements a much faster measurement rate will be needed. For proximity sensing, the current consumption of the VCNL4020C is primarily a function of the infrared emitter current and, secondarily, signal processing done by the ASIC. Example current consumption calculations are shown below for the range of IRED current and measurement rates. The current between burst pulse frames is equivalent to the standby mode. The duty cycle of the emitter is 50 %.

<b>1 measurement per second, emitter current = 200 mA</b>	
ASIC: 2.71 mA x 164 $\mu$ s x 1/1 s =	<b>0.45 <math>\mu</math>A</b>
IRED: 200 mA x 153 $\mu$ s x 0.5 x 1/1 s =	<b>15.30 <math>\mu</math>A</b>
<b>total:</b>	<b>15.75 <math>\mu</math>A</b>
<b>100 measurement per second, emitter current = 20 mA</b>	
ASIC: 2.71 mA x 164 $\mu$ s x 100/1 s =	<b>44.5 <math>\mu</math>A</b>
IRED: 20 mA x 153 $\mu$ s x 0.5 x 100/1 s =	<b>153.0 <math>\mu</math>A</b>
<b>total:</b>	<b>197.5 <math>\mu</math>A</b>

## Designing the VCNL4020C into an Application

### SENSOR INITIALIZATION

The VCNL4020C contains seventeen 8-bit registers for operation control, parameter setup, and result buffering. All registers are accessible via I<sup>2</sup>C communication. The built-in I<sup>2</sup>C interface is compatible with all I<sup>2</sup>C modes: standard, fast, and high speed. The I<sup>2</sup>C H-level voltage range is from 1.7 V to 5.0 V.

There are only three registers out of the seventeen that typically need to be defined:

1. IRED Current = 10 mA to 200 mA  
**IR LED Current Register #3 [83h]**
2. Biosensor Measurement Rate = 1.95 meas/s to 250 meas/s  
**Biosensor Rate Register #2 [82h]**
3. Biosensor and Light Sensor: number of consecutive measurements above / below threshold:
  - int\_count\_exceed = 1 to 128  
defines number of consecutive measurements above threshold
  - int\_thres\_en = 1  
enables interrupt when threshold is exceeded
  - int\_thres\_sel = 0  
defines thresholds for proximity

#### Interrupt Control Register # 9 [89h].

For ambient light sensing, the default averaging value is 32 measurements. If this value needs to be changed or if "Continuous Conversion" mode is desired, a fourth register may be defined:

4. ALS Measurement Rate, auto offset = on, averaging  
**Ambient Light Parameter Register # 4 [84h]**

Fig. 13 shows the typical digital counts output vs. distance for three different emitter currents. The reflective reference medium is the Kodak Gray card. This card shows approximately 18 % reflectivity at 890 nm.

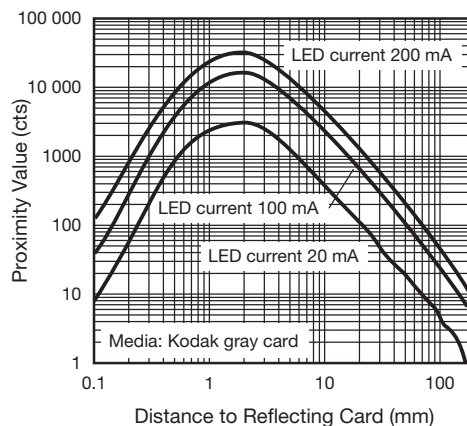

Fig. 13 - Proximity Value vs. Distance

The biosensor measurement rate determines how fast the application reacts when an object appears in, or is removed from, the proximity zone. Reaction time is also determined by the number of counts that must be exceeded before an interrupt is set.

To define these register values, evaluation tests should be performed. The sensor starter kit allows you to perform evaluation tests and properly set the registers for your application. The kit is available from any of Vishay's distributors. It comes with the VCNL4020 sensor board. The VCNL4020C sensor board can be requested by sending an e-mail to [sensorstechsupport@vishay.com](mailto:sensorstechsupport@vishay.com).

## Designing the VCNL4020C into an Application

### Timing

For an I<sup>2</sup>C bus operating at 100 kHz, an 8-bit write or read command plus start, stop, and acknowledge bits takes 100  $\mu$ s. When the device is powered on, the initialization with just these three registers needs three write commands, each requiring three bytes: slave address, register, and data.

### Power Up

The release of internal reset, the start of the oscillator, and signal processor need **2.5 ms**

### Initialize Registers

Write to three registers **900  $\mu$ s**

- IR LED current
- Biosensor rate
- Interrupt control

Once the device is powered on and the VCNL4020C is initialized, a proximity measurement can be taken. Before the first read out of the proximity count, a wait time is required. Subsequent reads do not require this wait time.

Start measurement	<b>300 <math>\mu</math>s</b>
Measurement being made	<b>170 <math>\mu</math>s</b>
Wait time prior to first read	<b>400 <math>\mu</math>s</b>
Read out of the proximity data	<b>600 <math>\mu</math>s</b>
Total:	<b>1470 <math>\mu</math>s</b>

### AMBIENT LIGHT SENSING

Ambient light sensors are used to detect light or brightness in a manner similar to the human eye. They allow settings to be adjusted automatically in response to changing ambient light conditions. By turning on, turning off, or adjusting features, ambient light sensors can conserve battery power or provide extra safety while eliminating the need for manual adjustments.

Illuminance is the measure of the intensity of a light incident on a surface and can be correlated to the brightness perceived by the human eye. In the visible range, it is measured in units called "lux." Light sources with the same lux measurement appear to be equally bright. In Fig. 14, the incandescent light and sunlight have been scaled to have the same lux measurement. In the infrared region, the intensity of the incandescent light is significantly higher. A standard silicon photodiode is much more sensitive to infrared light than visible light. Using it to measure ambient light will result in serious deviations between the lux measurements of different light sources and human-eye perception. Using Vishay's ambient light sensors will solve this problem because they are most sensitive to the visible part of the spectrum.

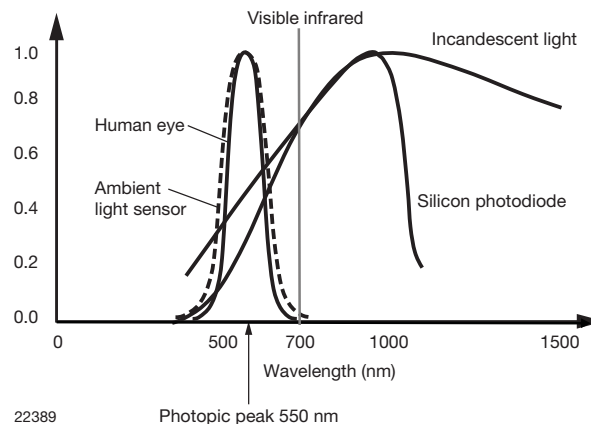

Fig. 14 - Relative Spectral Sensitivity vs. Wavelength

The human eye can see light with wavelengths from 400 nm to 700 nm. The ambient light sensor closely matches this range of sensitivity and provides a digital output based on a 16-bit signal.

## Designing the VCNL4020C into an Application

### AMBIENT LIGHT MEASUREMENT, RESOLUTION, AND OFFSET

The ambient light sensors' measurement resolution is 0.25 lux/count. The 16-bit digital resolution is equivalent to 65 536 counts. This yields a measurement range from 0.25 lux to 16 383 lux.

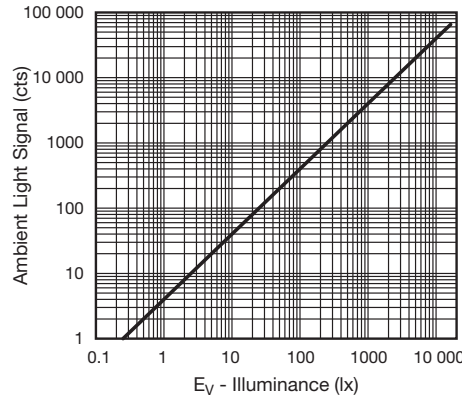

Fig. 15 - Ambient Light Values vs. Illuminance

In most applications a cosmetic window or cover is placed in front of the sensor. These covers reduce the amount of light reaching the sensor. It is not uncommon for only 10 % of the ambient light to pass through the window. The resulting sensor resolution in relation to cover transparency is shown in Table 1.

TABLE 1 - RESOLUTION VS. TRANSPARENCY	
COVER VISIBLE LIGHT TRANSPARENCY (%)	RESULTING SENSOR RESOLUTION (LUX/COUNT)
100	0.25
50	0.5
20	1.25
10	2.5

Similar to the proximity measurements, there is a digital offset deviation of -3 counts, which has to be considered when setting up the application thresholds. This offset comes from tolerances within the digital compensation process. In single-digit lux ambient lighting, where the transparency of the window is 10 % or less, these three counts should be added to the actual ambient light value.

### AMBIENT LIGHT SENSOR CURRENT CONSUMPTION

The ambient light sensor can operate in single or continuous mode. In single-mode operation, an ambient light measurement consists of up to 128 individual measurement cycles, which are averaged. The timing diagram for an individual measurement cycle is shown in Fig. 16.

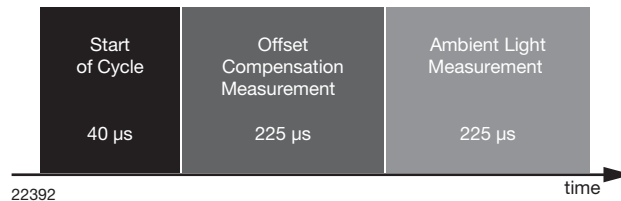

Fig. 16 - Timing Diagram for Individual Measurement Cycle



## Designing the VCNL4020C into an Application

In single-mode operation, an ambient light measurement takes 100 ms. The single measurement cycles are evenly spread inside this 100 ms frame. Fig. 17 shows an example where eight single measurement cycles are averaged. The maximum number of single measurement cycles that can be used to calculate an average is 128. The maximum number of times this average can be calculated in one second is 10.

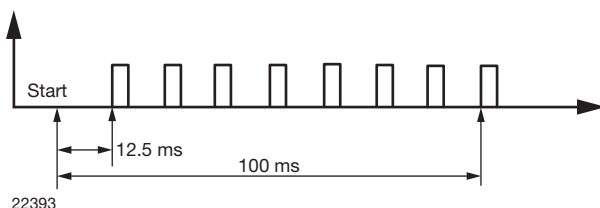

Fig. 17 - Ambient Light Measurement With Averaging = 8

A higher number of measurement cycles increases the accuracy of the reading and reduces the influence of modulated light sources. However, a higher number of cycles also consumes more power. During an individual measurement cycle, the ASIC consumes approximately 2.7 mA. Between the individual measurements, the current consumption is 9 μA. Example current consumption calculations are shown below.

**Current Calculations for Ambient Light Measurements:**

**1 measurement per second, AVG = 32**

$$2.7 \text{ mA} \times 450 \text{ } \mu\text{s}/1 \text{ cycle} \times 32 \text{ cycles} \times 1 = 39 \text{ } \mu\text{A}$$

**10 measurement per second, AVG = 128**

$$2.7 \text{ mA} \times 450 \text{ } \mu\text{s}/1 \text{ cycle} \times 128 \text{ cycles} \times 10 = 1.55 \text{ mA}$$

The current consumption for the ambient light sensor is strongly dependent on the number of measurements taken. In single-mode operation, the highest average current is 1.55 mA. Fig. 18 shows that increasing the number of cycles averaged reduces the standard deviation of the measurement.

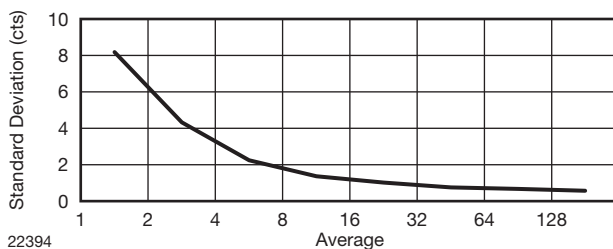

Fig. 18 - Ambient Light Noise vs. Averaging

In continuous conversion mode, the ambient light sensor measurement time can be reduced. A timing example of continuous mode where eight measurements are averaged is shown in Fig. 19.

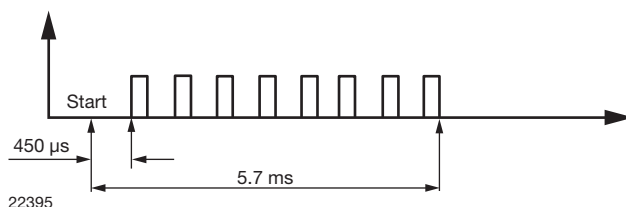

Fig. 19 - Ambient Light Measurement With Averaging = 8 Using Continuous Conversion Mode



## Designing the VCNL4020C into an Application

The individual measurements are done sequentially. Recall that one individual measurement cycle, including offset compensation, takes approximately 450  $\mu$ s. The gap time is 180  $\mu$ s. As shown in Fig. 19, the result of the eight cycles is already accessible after about 6 ms. However, fluorescent light suppression is less effective in this mode.

There will be no influence on the ambient measurement from the infrared emitter used for proximity because the proximity measurements are made between the ambient light measurements. They are not performed at the same time.

### AMBIENT LIGHT INITIALIZATION

For ambient light sensing, only register #4 parameters need to be initialized:

- Continuous conversion ON / OFF (register #4b7)
- Offset compensation ON / OFF (register #4b3)
- Number of average measurements (register #4b0 to 4b2)

The default settings are:

- Continuous conversion = OFF
- Offset compensation = ON
- Number of average measurements = 32

### INTERRUPT

The VCNL4020C features an interrupt function. The interrupt function enables the sensor to work independently until a predefined proximity or ambient light event or threshold occurs. It then sets an interrupt that requires the microcontroller to awaken. This helps customers reduce their software effort, and reduces power consumption by eliminating polling communication traffic between the sensor and microcontroller. The interrupt pin, pin 3 of the VCNL4020C, should be connected to a dedicated GPIO of the controller. A pull-up resistor is added to the same power supply to which the controller is connected. This INT pull-up resistor may be in the range of 1 k $\Omega$  to 100 k $\Omega$ . Its current sinking capability is greater than 8 mA, typically 10 mA, and less than 20 mA.

The events that can generate an interrupt include:

1. A lower and an upper threshold for the proximity value can be defined. If the proximity value falls below the lower limit or exceeds the upper limit, an interrupt event will be generated. In this case, an interrupt flag bit in the interrupt status register will be set and the interrupt pad of the ASIC will be pulled to low by an open drain pull-down circuit. In order to eliminate false triggering of the interrupt by noise or disturbances, it is possible to define the number of consecutive measurements that have to occur before the interrupt is triggered
2. Lower and upper thresholds for the ambient light value can be defined. If the ambient light value falls below the lower limit or exceeds the upper limit, an interrupt event will be generated. There is only one set of high and low threshold registers. You will have to decide if the thresholds will be defined for proximity or ambient light
3. An interrupt can be generated when a proximity measurement is ready
4. An interrupt can be generated when an ambient light measurement is ready

For each of these conditions a separate bit can activate or deactivate the interrupt. This means that a combination of different conditions can occur simultaneously. Only condition 1 and 2 cannot be activated at the same time. For them, one bit indicates that the threshold interrupt is on or off, a second bit indicates if it is for proximity or ambient light.

When an interrupt is generated, the information about the condition that has generated the interrupt will be stored and is available for the user in an interrupt status register, which can be read out via I<sup>2</sup>C. Each condition that can generate an interrupt has a dedicated result flag. This allows independent handling of the different conditions. For example, if the interrupt is generated by the upper threshold condition and a measurement ready condition, both flags are set.

To clear the interrupt line, the user has to clear the enabled interrupt flag in the interrupt status register, register 14. Resetting the interrupt status register is done with an I<sup>2</sup>C write command. One interrupt bit can be cleared without affecting another. If there was a second interrupt source, it would have to be cleared separately. With a write command where all four interrupt bits are set to "1", all these bits and the interrupt line are cleared or reset.



## Designing the VCNL4020C into an Application

### REGISTER FUNCTIONS

#### Register #0 Command Register

The register address = 80h.

The register #0 is for starting ambient light or biosensor measurements. This register contains two flag bits for data-ready indication.

TABLE 2 - COMMAND REGISTER #0							
Bit 7	Bit 6	Bit 5	Bit 4	Bit 3	Bit 2	Bit 1	Bit 0
config_lock	als_data_rdy	bs_data_rdy	als_od	bs_od	als_en	bs_en	selftimed_en
Description							
config_lock		Read-only bit. Value = 1					
als_data_rdy		Read-only bit. Value = 1 when ambient light measurement data is available in the result registers. This bit will be reset when one of the corresponding result registers (reg #5, reg #6) is read					
bs_data_rdy		Read-only bit. Value = 1 when biosensor measurement data is available in the result registers. This bit will be reset when one of the corresponding result registers (reg #7, reg #8) is read					
als_od		R / W bit. Starts a single on-demand measurement for ambient light. If averaging is enabled, starts a sequence of readings and stores the averaged result. The result is available at the end of conversion for reading in the registers #5 (HB) and #6 (LB).					
bs_od		R / W bit. Starts a single on-demand measurement for the biosensor. The result is available at the end of conversion for reading in the registers #7 (HB) and #8 (LB)					
als_en		R / W bit. Enables periodic ALS measurement					
bs_en		R / W bit. Enables periodic biosensor measurement					
selftimed_en		R / W bit. Enables state machine and LP oscillator for self-timed measurements; no measurement is performed until the corresponding bit is set					

#### Note

- With setting bit 3 and bit 4 at the same write command, a simultaneous measurement of ambient light and biosensor is done. Besides als\_en and / or bs\_en, the first selftimed\_en needs to be set. On-demand measurement modes are disabled if the selftimed\_en bit is set. For the selftimed\_en mode, changes in reading rates (reg #4 and reg #2) can be made only when b0 (selftimed\_en bit) = 0. For the als\_od mode, changes to the reg #4 can be made only when b4 (als\_od bit) = 0; this is to avoid synchronization problems and undefined states between the clock domains. In effect this means that it is only reasonable to change rates while no self-timed conversion is ongoing.

#### Register #1 Product ID Revision Register

The register address = 81h. This register contains information about product ID and product revision.

The register data value of current revision = 21h.

TABLE 3 - PRODUCT ID REVISION REGISTER #1							
Bit 7	Bit 6	Bit 5	Bit 4	Bit 3	Bit 2	Bit 1	Bit 0
Product ID				Revision ID			
Description							
Product ID		Read-only bits. Value = 2					
Revision ID		Read-only bits. Value = 1					

APPLICATION NOTE



## Designing the VCNL4020C into an Application

### Register #2 Rate of Biosensor Measurement

The register address = 82h.

TABLE 4 - BIOSENSOR RATE REGISTER #2							
Bit 7	Bit 6	Bit 5	Bit 4	Bit 3	Bit 2	Bit 1	Bit 0
n/a					Rate of biosensor measurement (no. of measurements per second)		
Description							
Biosensor rate	R / W bits. 000 - 1.95 measurements/s (DEFAULT) 001 - 3.90625 measurements/s 010 - 7.8125 measurements/s 011 - 16.625 measurements/s 100 - 31.25 measurements/s 101 - 62.5 measurements/s 110 - 125 measurements/s 111 - 250 measurements/s						

**Note**

- If the self\_timed measurement is running, any new value written in this register will not be taken over until the mode is actually cycled.

### Register #3 LED Current Setting for Biosensor Mode

The register address = 83h. This register is to set the LED current value for biosensor measurement.

The value is adjustable in steps of 10 mA from 0 mA to 200 mA.

This register also contains information about the used device fuse program ID.

TABLE 5 - LED CURRENT REGISTER #3							
Bit 7	Bit 6	Bit 5	Bit 4	Bit 3	Bit 2	Bit 1	Bit 0
Fuse prog ID		LED current value					
Description							
Fuse prog ID	Read-only bits. Information about the fuse program revision used for the initial setup / calibration of the device						
LED current value	R / W bits. LED current = value (dec.) x 10 mA Valid range = 0 d to 20 d, e.g. 0 = 0 mA, 1 = 10 mA, ..., 20 = 200 mA (2 = 20 mA = DEFAULT) LED current is limited to 200 mA for values higher than 20 d						



Designing the VCNL4020C into an Application

Register #4 Ambient Light Parameter Register

The register address = 84h.

TABLE 6 - AMBIENT LIGHT PARAMETER REGISTER #4. Table with 8 columns (Bit 7 to Bit 0) and 5 rows. Rows include: Cont. conv. mode, als\_rate, Auto offset compensation, Averaging function, and a detailed Description section for each parameter.

Note

- If the self\_timed measurement is running, any new value written in this register will not be taken over until the mode is actually cycled.

Register #5 and #6 Ambient Light Result Register

The register address = 85h and 86h. These registers are the result registers for ambient light measurement readings.

The result is a 16-bit value. The high byte is stored in register #5 and the low byte in register #6.

TABLE 7 - AMBIENT LIGHT RESULT REGISTER #5. Table with 8 columns (Bit 7 to Bit 0) and 2 rows. Row 1: Bit headers. Row 2: Description: Read-only bits. High byte (15:8) of ambient light measurement result.

TABLE 8 - AMBIENT LIGHT RESULT REGISTER #6. Table with 8 columns (Bit 7 to Bit 0) and 2 rows. Row 1: Bit headers. Row 2: Description: Read-only bits. Low byte (7:0) of ambient light measurement result.

APPLICATION NOTE



## Designing the VCNL4020C into an Application

### Register #7 and #8 Biosensor Measurement Result Register

The register address = 87h and 88h. These registers are the result registers for biosensor measurement readings.

The result is a 16-bit value. The high byte is stored in register #7 and the low byte in register #8.

TABLE 9 - BIOSENSOR RESULT REGISTER #7							
Bit 7	Bit 6	Bit 5	Bit 4	Bit 3	Bit 2	Bit 1	Bit 0
<b>Description</b>							
Read-only bits. High byte (15:8) of biosensor measurement result							

TABLE 10 - BIOSENSOR RESULT REGISTER #8							
Bit 7	Bit 6	Bit 5	Bit 4	Bit 3	Bit 2	Bit 1	Bit 0
<b>Description</b>							
Read-only bits. Low byte (7:0) of biosensor measurement result							

### Register #9 Interrupt Control Register

The register address = 89h.

TABLE 11 - INTERRUPT CONTROL REGISTER #9							
Bit 7	Bit 6	Bit 5	Bit 4	Bit 3	Bit 2	Bit 1	Bit 0
Int count exceed			n/a	INT_BS_ready_EN	INT_ALS_ready_EN	INT_THRES_EN	INT_THRES_SEL
<b>Description</b>							
Int count exceed	R / W bits. These bits contain the number of consecutive measurements needed above / below the threshold 000 - 1 count = DEFAULT 001 - 2 count 010 - 4 count 011 - 8 count 100 -16 count 101 - 32 count 110 - 64 count 111 - 128 count						
INT_BS_ready_EN	R / W bit. Enables interrupt generation at biosensor data ready						
INT_ALS_ready_EN	R / W bit. Enables interrupt generation at ambient data ready						
INT_THRES_EN	R / W bit. Enables interrupt generation when high or low threshold is exceeded						
INT_THRES_SEL	R / W bit. If 0: thresholds are applied to biosensor measurements. If 1: thresholds are applied to ALS measurements						



## Designing the VCNL4020C into an Application

### Register #10 and #11 Low Threshold

The register address = 8Ah and 8Bh. These registers contain the low threshold value. The value is a 16-bit word. The high byte is stored in register #10 and the low byte in register #11.

TABLE 12 - LOW THRESHOLD REGISTER #10							
Bit 7	Bit 6	Bit 5	Bit 4	Bit 3	Bit 2	Bit 1	Bit 0
<b>Description</b>							
R / W bits. High byte (15:8) of low threshold value							

TABLE 13 - LOW THRESHOLD REGISTER #11							
Bit 7	Bit 6	Bit 5	Bit 4	Bit 3	Bit 2	Bit 1	Bit 0
<b>Description</b>							
R / W bits. Low byte (7:0) of low threshold value							

### Register #12 and #13 High Threshold

The register address = 8Ch and 8Dh. These registers contain the high threshold value. The value is a 16-bit word. The high byte is stored in register #12 and the low byte in register #13.

TABLE 14 - HIGH THRESHOLD REGISTER #12							
Bit 7	Bit 6	Bit 5	Bit 4	Bit 3	Bit 2	Bit 1	Bit 0
<b>Description</b>							
R / W bits. High byte (15:8) of high threshold value							

TABLE 15 - HIGH THRESHOLD REGISTER #13							
Bit 7	Bit 6	Bit 5	Bit 4	Bit 3	Bit 2	Bit 1	Bit 0
<b>Description</b>							
R / W bits. Low byte (7:0) of high threshold value							

### Register #14 Interrupt Status Register

The register address = 8Eh. This register contains information about the interrupt status for either the biosensor or ALS function, and indicates if the high or low going threshold is exceeded.

TABLE 16 - INTERRUPT STATUS REGISTER #14							
Bit 7	Bit 6	Bit 5	Bit 4	Bit 3	Bit 2	Bit 1	Bit 0
n/a				int_bs_ready	int_als_ready	int_th_low	int_th_hi
<b>Description</b>							
int_bs_ready		R / W bit. Indicates a generated interrupt for the biosensor					
int_als_ready		R / W bit. Indicates a generated interrupt for the ALS					
int_th_low		R / W bit. Indicates a low threshold exceeded					
int_th_hi		R / W bit. Indicates a high threshold exceeded					

#### Note

- Once an interrupt is generated, the corresponding status bit goes to 1 and stays there unless it is cleared by writing a 1 in the corresponding bit. The int pad will be pulled down while at least one of the status bit is 1.



## Designing the VCNL4020C into an Application

### Register #15 Biosensor Modulator Timing Adjustment

The register address = 8Fh.

TABLE 17 - BIOSENSOR MODULATOR TIMING ADJUSTMENT #15							
Bit 7	Bit 6	Bit 5	Bit 4	Bit 3	Bit 2	Bit 1	Bit 0
Modulation delay time			Biosensor frequency		Modulation dead time		
Description							
Modulation delay time		R / W bits. Setting a delay time between the LED signal and detectors input signal evaluation. This function is for compensation of delays from the LED and photo diode. Also in respect to the possibility for setting different proximity signal frequency. Correct adjustment optimizes measurement signal level. (DEFAULT = 0)					
Biosensor frequency		R / W bits. Setting the biosensor test signal frequency. The biosensor measurement is using a square signal as the measurement signal. Four different values are possible: 00 = 390.625 kHz (DEFAULT) 01 = 781.25 kHz 10 = 1.5625 MHz 11 = 3.125 MHz					
Modulation dead time		R / W bits. Setting a dead time in the evaluation of the LED signal at the slopes of the signal. (DEFAULT = 1) This function is for reducing possible disturbance effects. This function reduces the signal level and should be used carefully					

User access for this register was maintained for applications using external infrared emitters. For applications using only the internal emitter, the default register values are already optimized for proximity operation: delay time = 0, proximity frequency = 390 kHz, and dead time = 1.

#### Modulation Delay Time

The proximity function works with a modulated signal. The proximity signal demodulator is frequency- and phase-sensitive, and references to the transmitted signal. In case of external infrared emitters with additional driver stages, there might be signal delays that could cause signal loss. By adjusting the “delay time” setting, this additional delay can be compensated. The delay time can be set to values between 0 and 7. Using external infrared emitters, the optimum setting is determined by trying different settings. The setting with the highest readings for proximity at a certain reflection condition should be selected. Since most applications will use the internal emitter, the default value is 0.

#### Proximity Frequency

This parameter was used during the development of the VCNL4020. The default setting of f = 390 kHz is the optimum setting.

#### Modulation Dead Time

Due to the emitter rise and fall times, the modulation signal is not a perfect square wave. Instead a slight slope occurs at the start and end of the signal. The modulation dead time defines a time window or range where the slopes from the received modulated signal are blanked out. This function eliminates effects from slow slopes, glitches, and other noise disturbances on the received signal. If the modulation dead time is set too long, a portion of the reflected signal will be lost in addition to the rise time slope. The modulation dead time can be set to values between 0 and 7. The default setting is 1. This setting is sufficient to suppress noise transients. It is NOT recommended to use the value “0” as a “dead time” setting. When using an external driver and emitters, it might be necessary to adjust this parameter. An external driver might cause slow slopes, unstable readings, or higher noise. Such effects could be reduced by adjusting this parameter.



## Designing the VCNL4020C into an Application

### APPLICATION EXAMPLE

The following example will demonstrate the ease of using the VCNL4020C sensor as “wake-up” when an object / hand comes closer. Its use as a heart rate sensor is described within the next chapter. Customers are strongly encouraged to purchase a sensor starter kit and request a VCNL4020C sensor board from: [sensorstechsupport@vishay.com](mailto:sensorstechsupport@vishay.com).

#### Offset

During development, the application-specific offset counts for the sensor were determined. As previously mentioned, the offset count is affected by the components surrounding the VCNL4020C, the window or cover being used, the distance from the sensor to the cover, and emitter intensity, which is controlled by the forward current. In the following example, with a cover over the sensor and setting the emitter current to 100 mA, the offset counts are 5400 counts (Fig. 20). Offset counts vary by application and can be anywhere from 5000 counts to 20 000 counts. It is important to note that the offset count may change slightly over time due to, for example, the window becoming scratched or dirty, or being exposed to high temperature changes. If possible, the offset value should occasionally be checked and, if necessary, modified.

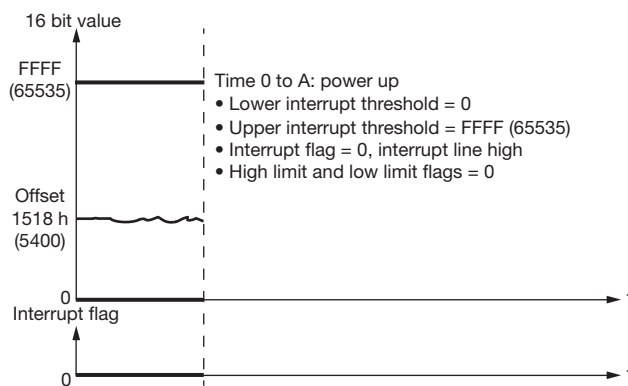

Fig. 20

#### Power Up

As mentioned, there are three variables that need to be set in the register when the sensor is powered up: the emitter current, the number of occurrences that must exceed a threshold to generate an interrupt, and the number of proximity measurements per second. For the application, the sensor should detect an object at 5 cm distance. Development testing determined that a current of 100 mA produces adequate counts for detection. The proximity measurement rate is set to 3.9 measurements per second and the number of occurrences to trigger an interrupt is set to two. Based on development testing, with a hand approximately 5 cm above the window cover, the resulting count is 5500. This will be used as the upper threshold.

For the wake-up feature, it would be typical to initially set only an upper threshold. However, in other sensing applications, a lower threshold may also be set. This creates an operating band where any change in the object’s position would trigger a threshold, as shown in Fig. 21.

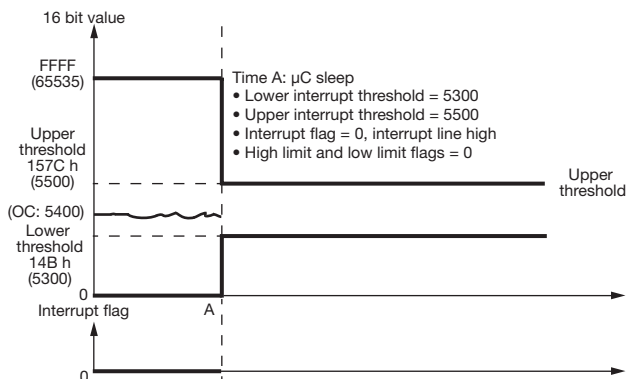

Fig. 21

## Designing the VCNL4020C into an Application

By setting the number of occurrences before generating an interrupt to two, a single proximity value above or below the thresholds will have no effect, as shown in Fig. 22.

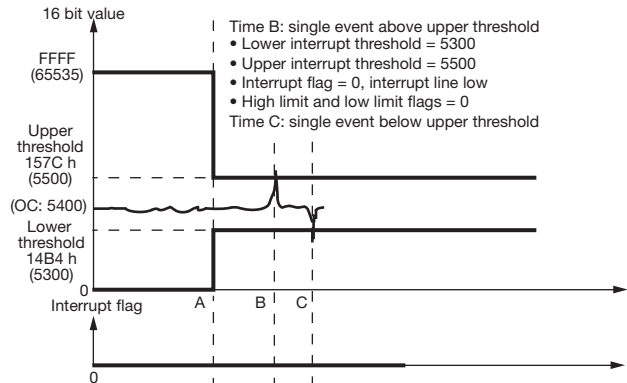

Fig. 22

Once an object is detected, the sensor can be switched to continuous polling or the thresholds can be reprogrammed. A smartphone application will use a proximity sensor to detect when the phone is brought to the user's ear and disable the touch screen and turn off the backlight. For other applications, the action taken when an object is detected is very application specific. For example, soap may be dispensed, paper towels may be unrolled, a blower turns on, or a lid is opened.

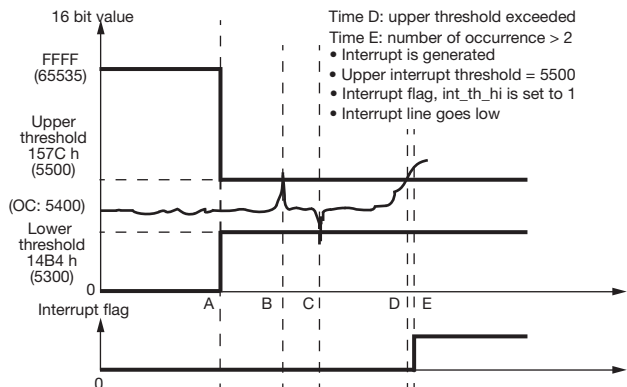

Fig. 23

In smartphone applications, the thresholds will be reprogrammed and the sensor will wait for another interrupt signal. In this case, the upper threshold should be set to a maximum value since the phone is already next to the user's ear and a lower threshold set so when the phone call is complete and the phone brought away from the ear, the backlight and touch screen will be turned back on.

The upper threshold needs to be set as high as possible since an interrupt has already been generated; set to FFFF (65535). The lower threshold is set to 5450 counts; a value that is higher than the offset but low enough to indicate the removal of the phone from the user's ear.

## Designing the VCNL4020C into an Application

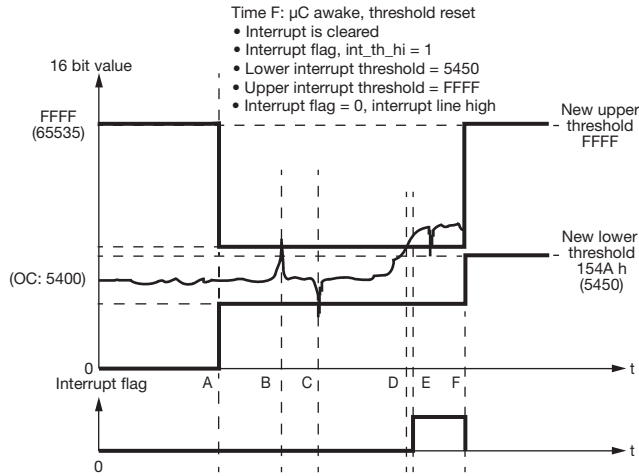

Fig. 24

When the object is removed, the sensor counts will return to 5400 counts and the lower threshold will generate an interrupt, `int_th_low` = 1.

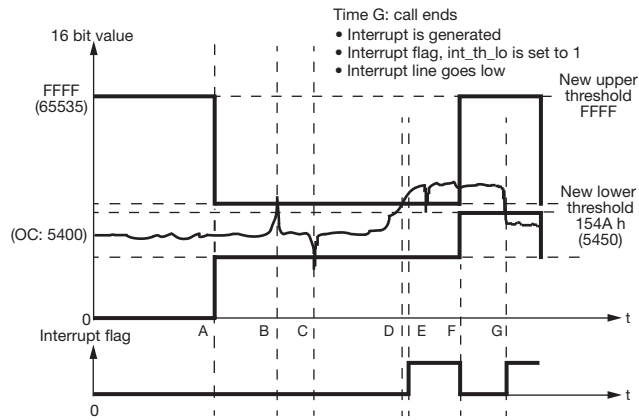

Fig. 25



## Designing the VCNL4020C into an Application

### EXAMPLE REGISTER SETTINGS FOR USE AS “WAKE-UP”

When the sensor is powered up the first time, the default register settings are made for the application.

ACTION	REGISTER SETTING
Set infrared emitter current to 200 mA	REGISTER #3 [83h]: 26, 83, 14
Set proximity measurement rate to 3.9 measurements/s	REGISTER # 2 [82h]: 26, 82, 01
Set ambient light sensor mode to normal, the measurement rate to 2 measurements/s, and the averaging to 32 conversions	REGISTER #4 [84h]: 26, 84, 1D
Set number of consecutive measurements that must occur to initiate an interrupt to two: Generate an interrupt when the threshold is exceeded ..... Thresholds are for proximity measurements .....	Register # 9 [89h]: 26, 89, 22 42 h: int_count_exceed = 2 int_thres_en = 1 int_thres_sel = 0

DEFAULT VALUE SET-UP ONLY AS HEXADECIMAL CODE IS:		
26, 83, 14	write: IRED current = 14	(= 200 mA)
26, 82, 01	write: Prox rate = 01	(= 4 measure/s)
26, 84, 1D	write: ALS mode = 1D	(= measure/s, auto-offset = on, averaging = 5)
26, 89, 22	write: Int cntr reg = 22	(= int_count_exceed = 2, int_thres_en = 1, int_thres_sel = 0)

Set an upper threshold for detecting an object and do not set a lower threshold.

ACTION	REGISTER SETTING
Set lower threshold value to 0 counts	Register #10 (8Ah): 26, 8A, 00 Register #11 (8Bh): 26, 8B, 00
Set upper threshold value to 5860 counts - 16E4 (hex)	Register #12 (8Ch): 26, 8C, 16 Register #13 (8Dh): 26, 8D, E4
Start self-timed periodic proximity measurements	Register #0 (80h): 26, 80, 03
Read interrupt status register	Register #14 (8Eh): 26, 8E, 27, xx

THIS PROXIMITY SET-UP SHOWN ONLY AS HEXADECIMAL CODE IS:		
26, 8A, 00	write: L_TH_HB = 00	
26, 8B, 00	write: L_TH_LB = 00	
26, 8C, 16	write: H_TH_HB = 16	
26, 8D, E4	write: H_TH_LB = E4	
26, 80, 03	write: 3: prox_en = 1, selftimed_en = 1	
WAIT	at least 400 μs	
26, 8E, 27, xx	read: xxxxxxx1, indicates int_th_hi = 1	



## Designing the VCNL4020C into an Application

### PROGRAM FLOW CHART

The initial setup for the proximity sensor. Note that default values do not need to be programmed.

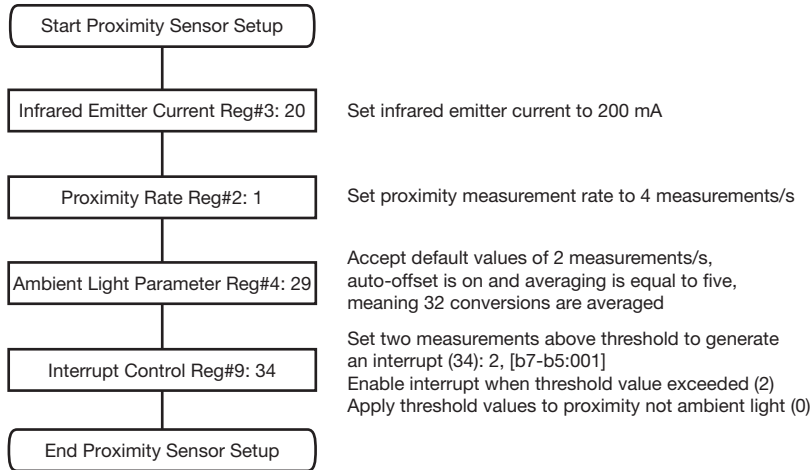

### Defining the Upper Threshold

The upper threshold value is set so that an interrupt is generated when an object comes close enough to the sensor to create a defined increase in counts. In this example, the offset counts are 5760 and the upper threshold is set 100 counts above the offset.

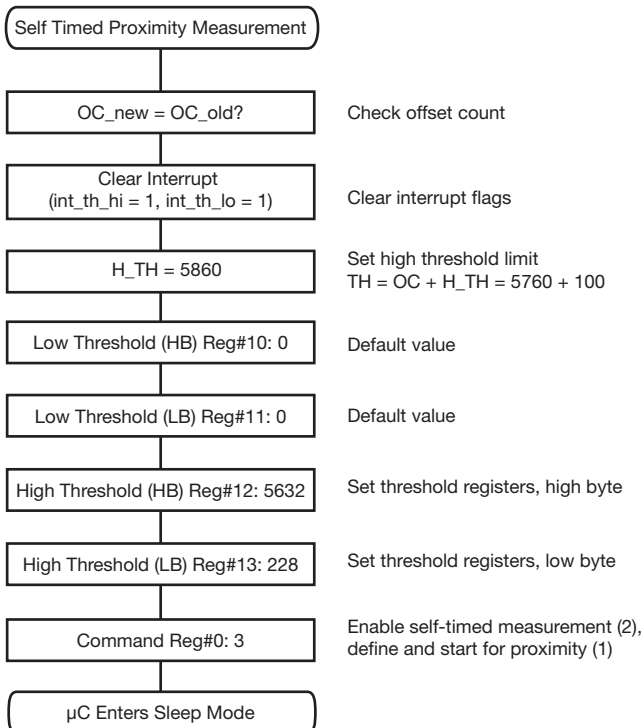

When an object does come close enough to the sensor to generate 100 counts and two consecutive measurements occur at or above this level, the interrupt line will go LOW and the interrupt can be read by the microcontroller in register 14, where int\_th\_hi will equal 1.

## Designing the VCNL4020C into an Application

### HEART RATE MEASUREMENT

The VCNL4020C combines an infrared emitter, a photodiode, an op-amp, a 16-bit A/D converter, and a signal and timing processor together with a programmable IRED / LED driver and connectivity for added external LEDs. The sensitivity of the photodiode allows for the detection of a wide spectra from low green ( $\leq 550$  nm) to IR wavelengths (950 nm).

The VCNL4020C sensor board (Fig. 35) comes with the sensor itself plus added external LEDs to fulfill all requests for accurate heart rate measurements. Allowing for the added VSMD66694 offers the possibility to measure with an external RED-LED and 940 nm IRED, plus a green LED placed nearby to also allow for measurement with this lower wavelength, which may show advantages.

To activate the desired LED / IRED, two ports from the controller within the USB dongle controlling all four possible emitters with help of few simple NAND devices.

The selection of the desired LED is possible within the “Setup” menu:



Fig. 26 - Selection for One LED Within VCNL4020C Demo Tool

The whole circuit diagram of the board is shown in Fig. 36.

To now do heart rate measurements, the demo software needs to be started and a finger placed to the small clear plastic cover above the LEDs and sensor.

By default it will be measured just with the VCNL4020C internal IRED. The needed emitter current may be as low as just 10 mA to 30 mA. For the red LED, 10 mA is enough for this tool to get no saturation due to the distance the cover used is from the sensor and the high sensitivity of the detector for this wavelength.

The VCNL demo tool would show this AC signal = heart rate, as shown in Fig. 34. The calculation for beats per minute (BPM) is simply done by multiplying the time between two absolute H peaks with 60. The time itself is given with the ratio between the total number of measurements between these two peaks and the available measurement rate (see Fig. 28).

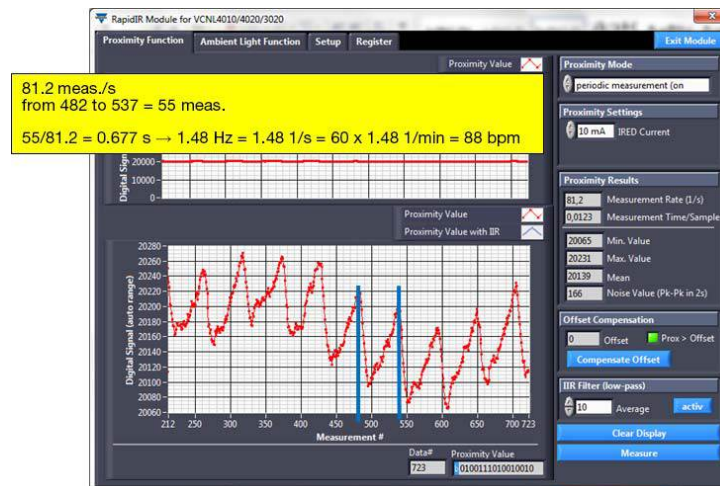

Fig. 27 - HRM Pulses Measured With VCNL4020C Evaluation Kit

## Designing the VCNL4020C into an Application

To see the exact measured data, one may just zoom for a proper period, having the mouse cursor within the window of the signal data and with the “left” tab zoom for just two maxima.

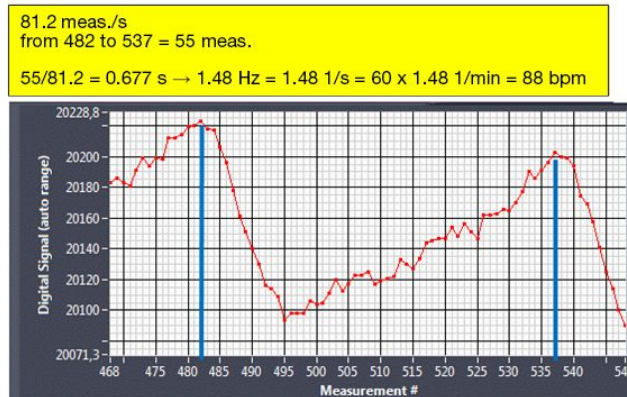

Fig. 28 - “Zoomed” Data

Exporting data to an Excel file is possible with just a “right click” within the data signal window. The window below will pop up:

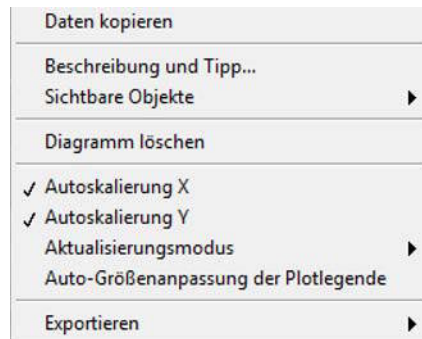

Fig. 29 - Copy Data to Excel File

“Exportieren” leads then to a second menu where the export to Excel is provided, and when chosen, an Excel spreadsheet will be opened with the data in it, which just needs to be saved to the desired folder.

The dedicated algorithm now detects the seen maxima, and with known measurement speed the BPM are calculated.

How this is possible to realize can be seen within the attached flow chart as well as an Excel file Vishay provides upon request.

Most commonly a transmissive mode is used, where a sensor is placed at a finger or the earlobe. Two LEDs are used with different wavelengths and a very sensitive detector measures the changing absorbance at either infrared or visible wavelengths.

## Designing the VCNL4020C into an Application

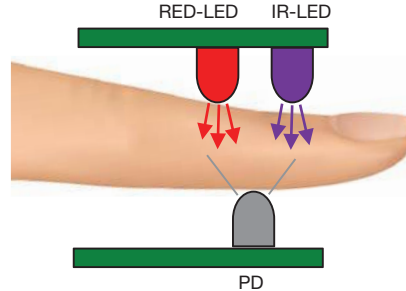

Fig. 30 - Sensing in Transmissive Mode

In addition to the transmissive mode, a reflective mode can also be used. Here the LEDs and the detector are located on the same side. A very well-designed light barrier is needed between the LEDs and detector.

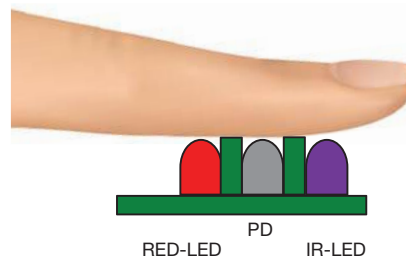

Fig. 31 - Sensing in Reflective Mode

The VCNL4020C digital sensor requires no additional light barriers, as its package serves this purpose quite well and the detector is not loaded with crosstalk directly from the LED chips.

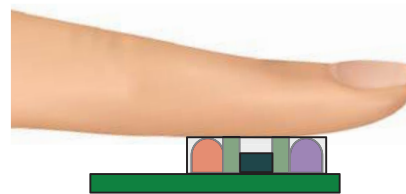

Fig. 32 - Sensing in Reflective Mode With the VCNL4020C



## Designing the VCNL4020C into an Application

Within the VCNL4020C sensor board, the double LED device VSMD66694 is placed close to the sensor. Here a red LED with a peak wavelength at 660 nm and a 940 nm IRED are packed together in a small 2 mm x 2 mm package.

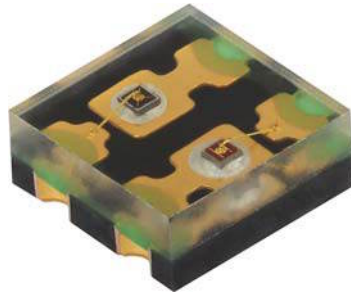

Fig. 33 - Double-LED Device: VSMD66694

The wavelengths now optimal for this measurement may depend on where the HRM is being performed, such as at a finger or earlobe. The photodiode receives the non-absorbed reflected light, the heart rate related pulsing signal, together with a big portion of light reflecting from venous blood, non-pulsatile blood, and tissue plus bones.

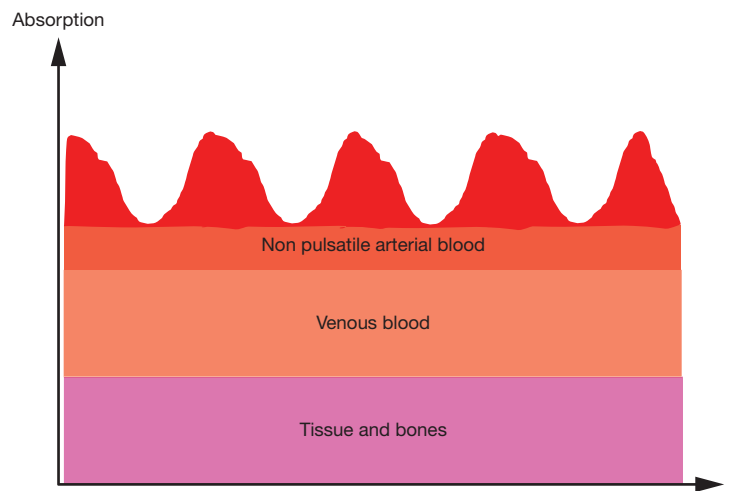

Fig. 34 - Heart Rate Pulsing and Other Reflected Light

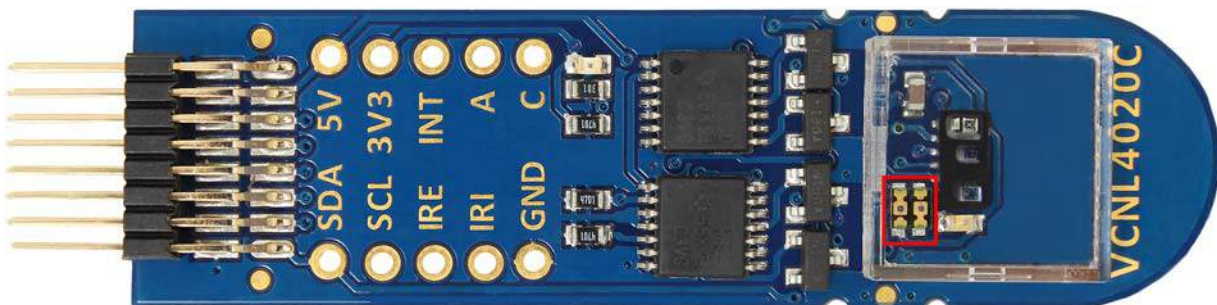

Fig. 35 - VCNL4020C Sensor Board With Added External LEDs

## Designing the VCNL4020C into an Application

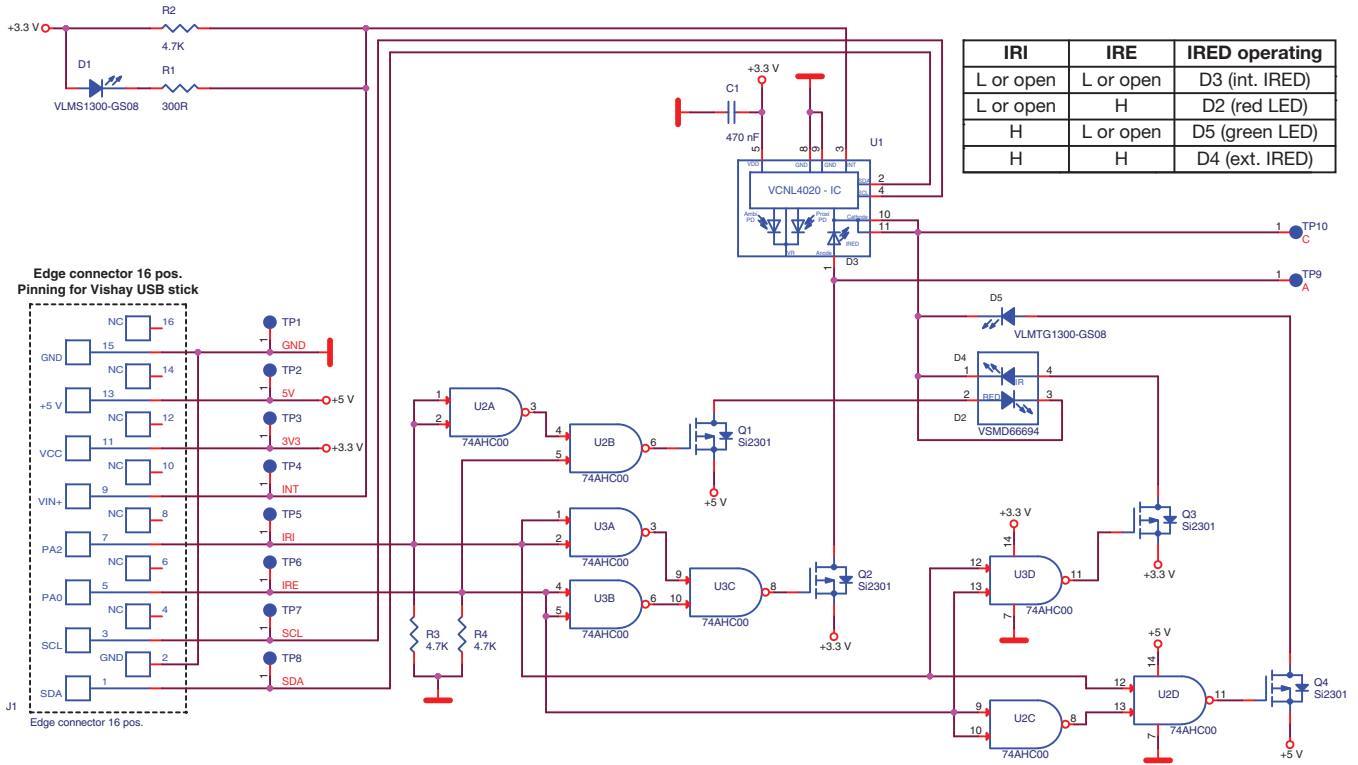

Fig. 36 - VCNL4020C Sensor Board Circuit Diagram



## **Disclaimer**

ALL PRODUCT, PRODUCT SPECIFICATIONS AND DATA ARE SUBJECT TO CHANGE WITHOUT NOTICE TO IMPROVE RELIABILITY, FUNCTION OR DESIGN OR OTHERWISE.

Vishay Intertechnology, Inc., its affiliates, agents, and employees, and all persons acting on its or their behalf (collectively, "Vishay"), disclaim any and all liability for any errors, inaccuracies or incompleteness contained in any datasheet or in any other disclosure relating to any product.

Vishay makes no warranty, representation or guarantee regarding the suitability of the products for any particular purpose or the continuing production of any product. To the maximum extent permitted by applicable law, Vishay disclaims (i) any and all liability arising out of the application or use of any product, (ii) any and all liability, including without limitation special, consequential or incidental damages, and (iii) any and all implied warranties, including warranties of fitness for particular purpose, non-infringement and merchantability.

Statements regarding the suitability of products for certain types of applications are based on Vishay's knowledge of typical requirements that are often placed on Vishay products in generic applications. Such statements are not binding statements about the suitability of products for a particular application. It is the customer's responsibility to validate that a particular product with the properties described in the product specification is suitable for use in a particular application. Parameters provided in datasheets and / or specifications may vary in different applications and performance may vary over time. All operating parameters, including typical parameters, must be validated for each customer application by the customer's technical experts. Product specifications do not expand or otherwise modify Vishay's terms and conditions of purchase, including but not limited to the warranty expressed therein.

Except as expressly indicated in writing, Vishay products are not designed for use in medical, life-saving, or life-sustaining applications or for any other application in which the failure of the Vishay product could result in personal injury or death. Customers using or selling Vishay products not expressly indicated for use in such applications do so at their own risk. Please contact authorized Vishay personnel to obtain written terms and conditions regarding products designed for such applications.

No license, express or implied, by estoppel or otherwise, to any intellectual property rights is granted by this document or by any conduct of Vishay. Product names and markings noted herein may be trademarks of their respective owners.